

~~SECRET~~

K-OA-1237

REDACTED COPY

3/4/64

File: Centrifuge  
Appraisal  
Reports

NUCLEAR POWER EVALUATION (U)

~~RESTRICTED DATA~~

~~This document contains restricted  
Data as defined by the Atomic Energy  
Act of 1954. Its transmission and disclosure  
Subject to Administrative and Criminal  
Sanctions.~~

AUTHORS

- S. A. Levin
- E. R. Powers
- E. Von Halle



20110000033

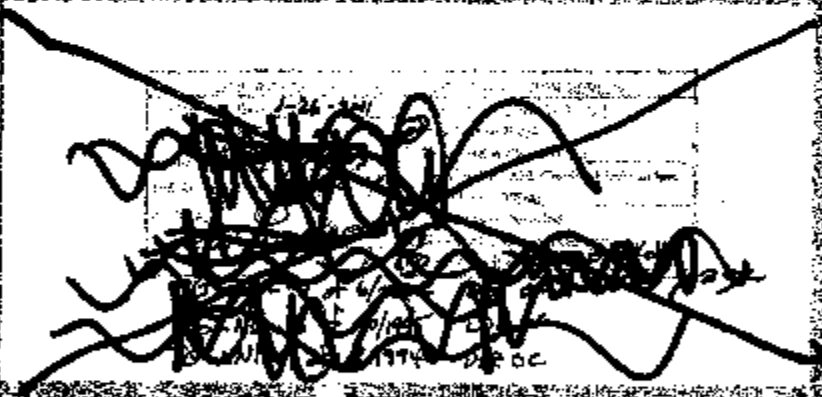

UNION CARBIDE CORPORATION  
NUCLEAR DIVISION

DAK RIDGE GASEOUS DIFFUSION PLANT  
OXFORD Y-12 PLANT

DAK RIDGE NATIONAL LABORATORY  
RADICAL GASEOUS DIFFUSION PLANT

~~SECRET~~

~~SECRET~~

~~SECRET~~

~~SECRET~~

THIS DOCUMENT CONSISTS OF 104 PAGE  
NO. 1 OF 1 COPIES, SERIES D

Date of Issue: March 4, 1964

Report Number: K-CA-1237

KOA 1237 1 D



\*KOA 1237 1 D\*

Nth POWER EVALUATION (a)

S. A. Levin  
L. R. Powers  
E. Von Halle

Operations Analysis Division  
D. M. Lang, Superintendent

UNION CARBIDE CORPORATION  
NUCLEAR DIVISION  
Oak Ridge Gaseous Diffusion Plant  
Oak Ridge, Tennessee

~~RESTRICTED AREA~~

~~This document contains restricted data as defined  
in the Atomic Energy Act of 1954. Its transmittal  
or the disclosure of its contents in any manner to  
an unauthorized person is prohibited.~~

~~GROUP I~~

~~Excluded from automatic down-  
grading and declassification.~~

~~SECRET~~

~~SECRET~~

Report Number: K-CA-1237

Title: Nth POWER EVALUATION

## ABSTRACT

In this report, an attempt is made to correlate the probability of some country (an Nth power) successfully producing a nuclear weapon or weapons by means of an overt or clandestine program involving the production and operation of a gas centrifuge plant with the industrial capability of that country. For this purpose the countries of interest have been divided into three groups designated by X, Y, and Z. Group X countries are those possessing a relatively high degree of technical competence and which have a high degree of industrial activity. Group Z countries are those which possess relatively little technical skills and which have relatively little industrial activity. Group Y countries are those which lie between and have limited internal industrial activity.

The over-all time, investment, and work force required for the construction of a centrifuge weapons facility and the cost and manpower required for its operation for various centrifuge models is presented for X, Y, and Z nations. It is felt that it is feasible for the countries described in this report which do not have a nuclear weapons program to produce enriched uranium by means of a small gas centrifuge plant.

The current status of gas centrifuge development programs in foreign non-Communist countries is reviewed on the basis of information obtained from both the open and classified scientific literature, the press, and intelligence reports.

This report supersedes reports KOA-662 and KOA-916 prepared at Oak Ridge in 1960 and 1962.

~~SECRET~~

~~SECRET~~

~~SECRET~~

~~SECRET~~

TABLE OF CONTENTS

Introduction..... 9

Summary..... 11

Plant Description..... 24

    Centrifuge Facility..... 24

    Zippe Centrifuge..... 24

    Present 6-Inch Subcritical Centrifuge..... 26

    Proposed Subcritical Centrifuge..... 27

    Proposed Supercritical Centrifuge..... 27

    Future Subcritical Centrifuge..... 30

    Future Supercritical Centrifuge..... 30

Centrifuge Plant Characteristics..... 31

    Plant Layout..... 31

    Electrical Equipment..... 38

    Process Piping..... 40

    Process Controls..... 40

    Process Auxiliaries..... 42

    Operating Costs..... 45

Feed Plant..... 46

Metals Plant..... 47

Discussion..... 72

    Feasibility of Clandestine Operation..... 72

    Minimum Time Required to Produce the First Nuclear Weapon..... 74

    Operating and Maintenance..... 74

    Capital and Operating Cost Estimates..... 74

    Key Areas Indicating Potential for Weapons Production..... 75

Correlation of Industrial Capability of Nations..... 75

Clandestine Production of Enriched Uranium by the Sweep Diffusion Process..... 78

Review and Evaluation of Foreign Centrifuge Programs..... 80

    Introduction..... 80

    Brazil..... 81

    England..... 82

    Japan..... 86

    The Netherlands..... 91

    West Germany..... 93

    Other Foreign Countries..... 99

Acknowledgements..... 100

References..... 101

~~SECRET~~

~~TOP SECRET~~

~~SECRET~~

SECRET

~~SECRET~~

LIST OF TABLES

1	Description of Centrifuge Models.....	16
2	Gas Centrifuge Plant Summary for Class X Nations.....	17
3	Gas Centrifuge Plant Summary for Class Y Nations.....	18
4	Gas Centrifuge Plant Summary for Class Z Nations.....	19
5	Gas Centrifuge Plant Summary for Class X Nations.....	20
6	Gas Centrifuge Plant Summary for Class Y Nations.....	21
7	Gas Centrifuge Plant Summary for Class Z Nations.....	22
8	Minimum Time Required to Produce First Nuclear Weapon.....	23
9	Estimated Manpower and Capital for Centrifuge Plant Construction and Operation in U.S. - Model A, Original Zippe.....	49

DOE  
6.26

**DELETED**

20	Estimated Manpower and Capital for Feed Plant Construction and Operation in U.S., 25 TU Per Year.....	60
21	Estimated Manpower and Capital for Feed Plant Construction and Operation in U.S., 50 TU Per Year.....	61
22	Estimated Manpower and Capital for Feed Plant Construction and Operation in U.S., 100 Tu Per Year.....	62
23	Estimated Manpower and Capital for Feed Plant Construction and Operation in U.S., 500 TU Per Year.....	63
24	Estimated Manpower and Capital for Metal Component Facility Construction and Operation in U.S., 50 Kg U Per Year.....	64
25	Estimated Manpower and Capital for Metal Component Facility Construction and Operation in U.S., 500 Kg U Per Year.....	65

SECRET

~~SECRET~~

~~SECRET~~

~~SECRET~~

S

LIST OF FIGURES

1	Schematic Representation of Typical Zippe Centrifuge.....	25
2	Schematic Representation of the Proposed Subcritical Centrifuge.....	28
3	Schematic Representation of a Supercritical Centrifuge.....	29
4	One-Half of a 10-Centrifuge Parallel Cell.....	33
5	10-Centrifuge Parallel Cell.....	34
6	10-Centrifuge Series Cell (One Centrifuge Per Stage).....	36
7	Typical 10-Cell Sub Cascade.....	37
8	Typical Electrical Distribution System.....	39
9	Layout of Ideal Plants Containing Subcritical Centrifuges, Model A, 3 in., 350 m/sec.....	66

DOE  
6.2(a)

SECRET

15	Correlation of Relative Industrial Capabilities.....	77
16	Schematic Representation of a Sweep Diffusion Column.....	79

~~SECRET~~

~~SECRET~~





**DELETED**

Group Z countries are those which possess relatively little technical skills and which have relatively little industrial activity.

Group Y countries are those which lie between and which have limited internal industrial activity.

**DELETED**

For this evaluation, two sizes of production facilities are considered:

1. Capable of producing 50 kg per year of highly enriched U-235 which should be a sufficient amount of fissionable material for the fabrication of at least one nuclear weapon per year.
2. Capable of producing 500 kg per year of highly enriched U-235. This production rate should be about the upper limit for which the centrifuge process would be used.

The production facilities may be considered as consisting of three separate processes. These are:

1. The feed plant in which the ore concentrate is converted to process gas.
2. The isotope separation plant itself, in which the concentration of U-235 is raised from that of the feed (0.71 weight per cent) to that required for a nuclear weapon (greater than 90%).
3. The metal reduction plant, in which the material is converted to uranium metal and then machined to finished metal parts for the nuclear weapon.

Six centrifuge models are considered for the two production-rate plants studied. The centrifuge models considered can be broken into three categories based on the progress made in the AEC gas centrifuge development program:

1. Those centrifuges which could be operated without the necessity of other development work.
2. Those centrifuges which are presently being worked on and which may be operable within a year or two.
3. Those centrifuges which require considerable advances in materials and operational technology. These centrifuges might be available in about 5 to 10 years.

Table 1 presents a summary of the more important characteristics of the various centrifuge models. In Table 1, each of the centrifuge models is assigned a code letter which will be used to refer to the models in all of the following cost and summary tables. Model A, the original Zippe machine, is included only for comparison purposes and is not considered a feasible machine even for the smaller production rate.

DOE  
1.4(C)

DOE  
1.4(C)

DOE  
1.4(C)

SUMMARY

It is felt that it is feasible for the countries described in this report which do not now have a nuclear weapons program to produce enriched uranium by means of a small gas centrifuge plant. The centrifuge process lends itself to clandestine operation; however, in a country not having its own uranium ore supply, safeguards requiring adequate inspection would probably prohibit clandestine operation. A class X country would need no outside assistance, while a class Y country would probably have to import some of the hardware and auxiliary equipment necessary to fabricate the centrifuge plant. A class Z country would probably have to purchase prefabricated centrifuges and almost all of the auxiliary equipment for the centrifuge plant from foreign vendors. In addition, a class Z country would need technical advisors from the outside to aid in the construction and operation of the centrifuge plant.

A summary of the over-all time, investment, and work force required for construction of a centrifuge weapons facility and the cost and manpower required for its operation for each of the centrifuge models described in Table 1 is presented in Tables 2 through 4 for the X, Y, and Z nations for the 50 kg U-235 per year production rate and in Tables 5 through 7 for the 500 kg U-235 per year production rate. A detailed cost, time, and manpower breakdown of the centrifuge weapons facility for its three separate processes -- isotope separation plant, feed plant, and metals plant based on estimated United States requirements is also presented in the report. A correlation, which is used to obtain factors for converting United States requirements into requirements of other nations is presented in Figure 15.

**DELETED**

DOE  
1.4(K)

\_\_\_\_\_ The times presented, which assume knowledge of the details of a particular centrifuge model, reflect the time required by a class X, Y, or Z country to develop the centrifuge fabricating, operating, and cascading techniques to the point where detailed plant designs could be initiated plus the estimated time to build the plant and produce the first weapon. If no knowledge of the details of a centrifuge model is available from the United States or from some other highly advanced country, additional development time would be required which is reflected in the higher times presented in Table 8 for these cases.

The total capital investment which amounts to about \$43.5 million for the model C centrifuge facility (for the low production rate) coupled with operating costs of about \$4.5 million per year, will in the case of a class Z country be quite a burden on the economy. A class Z country would have to be highly motivated to undertake such an expensive project. However, it is estimated that these costs may be reduced by as much as 75% with the more advanced centrifuge models; these much lower costs would certainly make the project more feasible for a class Z country.

The physical concealment of the small centrifuge plant should present no problems because of the relatively small size of the plant. The ground area would range from a small fraction of an acre, maybe up to  $3/4$  acre, depending upon which centrifuge model was used. While the centrifuge plant might be about three stories high for conventional construction (this would not be noticeable in industrial areas of X and Y nations), the building height could be lowered without sacrificing much in additional cost. This would, however, increase the ground area required. The lower building height might be desirable in the case of class Z countries in which three-story buildings could not be easily camouflaged without using costly underground construction. The feed and metals processing facilities are relatively small operations, which could be performed within the centrifuge separation plant.

The power requirements for the centrifuge plant will be relatively small, ranging from 0.5 to 8.4 megawatts for the small plant and 2.9 to 21 megawatts for the large plant, depending upon which centrifuge model is assumed. The effluents from the centrifuge plant could be handled easily. The waste streams from the plant over a period of a year, which is essentially the same amount as the feed, could be contained in a relatively few 10-ton  $UF_6$  cylinders which could be stored conveniently anywhere within the plant. The off-gases from the feed and metals plant could probably be neutralized with caustic and the product deposited in seepage pits.

#### Factors Influencing the Choice of the Centrifuge Route in Countries X, Y, and Z

In a class X country the choice of whether to produce a limited amount of nuclear weapons by the centrifuge or the reactor route is not clear cut at present. The centrifuge has the potential for low capital and operating costs but the technology is unavailable in the unclassified literature and the centrifuge at the present time will present a higher risk of failure. It is felt, however, that a class X country will have the experienced scientists and engineers necessary to bring a centrifuge facility into successful operation. Therefore, those class X countries having an advanced centrifuge program of their own or access to the results of another country's program may choose the centrifuge route for attainment of their first nuclear weapons, if they plan on modest expansion of their nuclear capability in the future and/or foresee a use for either slightly or highly enriched uranium in their future nuclear energy programs. Those countries having no centrifuge program of their own and no access to the results of programs in other countries would not be likely to choose the centrifuge route. As more advanced centrifuge models are developed and the reliability of the centrifuge is established, the choice may well be overwhelmingly in favor of the centrifuge process in those countries having access to the results of the development effort.

In a class Y country, if the goal is primarily the achievement of a clandestine, very limited nuclear capability, the reactor-plutonium route would undoubtedly be more attractive from the standpoint of certainty at the present time because of the availability of information in the open

literature. Again, however, if the country has access to the results of advanced centrifuge development work and they plan a modest expansion of their initial nuclear capability in the future and/or foresee the need for enriched uranium in their future nuclear energy programs, they may risk following the centrifuge route for their initial nuclear capability. As the more advanced centrifuges are developed and the class Y country obtains detailed information about these advanced machines, their choice between the reactor-plutonium route or the centrifuge route could favor the centrifuge route.

A class Z country will find the construction and operation of either a centrifuge or plutonium facility a difficult task. These countries would need much help from a class X or Y country. Due to the nonindustrial nature of a class Z country, a completely clandestine facility could probably not be built. The choice of whether to build a centrifuge or plutonium facility in a class Z country would probably depend upon which appeared most attractive to the class X or Y country with which they were collaborating. It probably would be easier to justify a power reactor than an unspecified centrifuge facility, and if the primary objective is an attempt at a clandestine operation, the plutonium route would probably be followed. Again, as the more advanced centrifuges are developed, the centrifuge site will probably become smaller and easier to hide and the choice may swing to the use of the centrifuge method.

#### Security Considerations

The continued classification of centrifuge technology and the exercise of export control over advanced centrifuges or critical components by the United States and her allies is highly desirable. The declassification of the centrifuge development efforts by the United States or her allies, especially the work done in the past three years, will increase the number of countries which might obtain a nuclear capability through the centrifuge route and reduce the time required for the attainment of a nuclear capability by those countries presently considering the use of the centrifuge. The release of the results of future development work will have an even more pronounced effect, since it is expected that future work will make the centrifuge route more attractive from the standpoint of both time and money.

#### Key Items

There are certain key items which indicate the possibility that an Nth power may be constructing a centrifuge facility for enriched uranium production. The more important of these items are listed in the report.

#### Sweep Diffusion Process

Although only the centrifuge process has been considered in this report for the clandestine production of enriched uranium, there are other processes which might be better matched with the lower technological capabilities of Y and Z foreign powers. Such a process, for example, would be sweep diffusion. In the sweep diffusion process, a gaseous mixture

of isotopes is confined in a column across which flows a current of a third component called the sweep gas or sweep vapor. As the sweep vapor flows through the process gas mixture, it tends to sweep along the heavy, or less diffusible, component. A sweep diffusion plant requires process equipment such as nickel plated pipe and screen, rotary lobe blowers to move the process gas between columns, centrifugal pumps to pump the condensed sweep vapor to the evaporators, and the evaporators themselves.

A preliminary investigation of the sweep diffusion process for the separation of other isotopes is being considered; this investigation would also determine its potential for uranium isotope separation. One of the more serious problems which would have to be overcome is the solubility of process gas in the condensed sweep vapor.

#### Evaluation of Foreign Centrifuge Programs

The current status of gas centrifuge development programs in foreign non-Communist countries is reviewed and an evaluation of the program in each country is made with respect to its scope and direction, ultimate goals, and chances for success. The information used in the preparation of this report was obtained from the open and classified scientific literature, the press, and from intelligence documents which were made available for this purpose. This work supersedes a previous report<sup>(2)</sup>.

From the information available, it appears that only four foreign countries outside the Communist Bloc are still making any serious effort to develop a gas centrifuge process for the enrichment of the uranium isotopes. These are West Germany, England, the Netherlands, and Japan. In addition, Brazil is maintaining its small interest in the centrifuge process, and France has recently been reported engaged in centrifuge development.

In general, due, in large part, to the fact that the European nations agreed at the end of 1960 to impose security restrictions on all future information arising from their development programs, little new information has become available since the preparation of the report two years ago. Exceptions to this are England, with which the United States has an information exchange program, and Japan where probably for political reasons the work is entirely unclassified. Despite the scarcity of reliable information, it is most probable that as a result of the furor which centrifuge developments evoked in the press in 1960, almost every class X country has undertaken a centrifuge development effort of some sort, even if quite small.

**DELETED**

Of the five countries mentioned above, West Germany is probably carrying on the most extensive program. It is comprised both of the development work headed by Dr. W. Groth at Bonn and of the development program being pursued by DEGUSSA at Frankfurt under the direction of Dr. G. Zippe. The progress made by the Germans prior to the end of 1960 when the West

DOE  
1.4(C)

German Government classified all further developments can be assessed reasonably well from the available literature.

**DELETED**

*1.90*

It is planned to consolidate all of the German centrifuge work in a new facility at Julich near Aachen where the work will be conducted directly for the West German Government.

**DELETED**

*1.4*

The Japanese in 1958 initiated a modest centrifuge development program apparently aimed at the development of an economical Groth-type machine. It has recently been reported that the Japanese are also investigating a Zippe-type machine. Although the progress in their first two years of work on the centrifuge process was most impressive, the accomplishments made during the second two years of their program appear to be quite limited. Their work is not as yet classified.

Although it is known that centrifuge work has been going on in the Netherlands for some time, very little about their work has been made public. The Dutch, along with the Germans, have encouraged the use of centrifuges for a proposed Euratom isotope separating facility. In May of this year, the Netherlands announced that they are embarking on a three-year centrifuge development program which, if successful, will lead to a pilot plant for uranium isotope separation.

**DELETED**

*1.40*

All five of these countries have the stated or implied goal of developing an economical process for the production of U-235 for peaceful uses. However, as has already been pointed out in this report, a workable centrifuge process, regardless of the purpose for which it was developed, provides a capability for the production of nuclear weapons. While many of the scientists working on centrifuges are probably interested in separating uranium for power reactors as they claim, the national leaders supporting these programs may well be interested in eventually using the centrifuge process to obtain nuclear weapons.

TABLE 1  
DESCRIPTION OF CENTRIFUGE MODELS

Model	Description	Length, in.	Diameter, in.	Speed, m/sec	Material	Fabrication Technique	Separative Capacity SU (max.), kg U/yr	Separative Capacity SU (expected), kg U/yr	Overall Centrifuge Efficiency, %
A	Original Zippe	12	3	350	Al 7075	Extruded	1.12	0.377*	30*

**DELETED**

\* These figures represent actual measured separative capacities for these centrifuge models.  
All other efficiencies and separative capacities are calculated values.

DOE  
62 (a)

~~SECRET~~



TABLE 2

OAS CENTRIFUGE PLANT SUMMARY FOR CLASS X NATION,  
50 kg U PER YEAR AT 90% U-235

	Machine Type					
	A	C	G	F	H	I
Capital Investment, \$						
Centrifuge Plant	104,078,000	28,271,000	11,568,000	12,604,000	4,870,000	4,305,000
Feed Plant	7,606,000	2,150,000	1,918,000	1,918,000	1,060,000	1,060,000
Metals Plant	364,000	364,000	364,000	364,000	364,000	364,000
Total	107,068,000	30,785,000	13,850,000	14,986,000	7,094,000	6,549,000
Peak Construction Work Force						
Total Number of Men	1,420	860	440	580	280	200
Technical	100	60	50	30	20	20
Construction Manpower, Man-Months	30,790	0,250	3,940	3,540	2,450	2,110
Over-all Construction Time, yr	4.8	2.0	2.4	2.2	2.2	2.2
Operating Cost, \$/yr						
Centrifuge Plant	11,066,000	3,386,000	1,495,000	1,478,000	540,000	490,000
Feed Plant	621,000	497,000	429,000	429,000	412,000	412,000
Metals Plant	153,000	153,000	153,000	153,000	153,000	153,000
Total	11,840,000	4,036,000	2,077,000	2,060,000	1,105,000	1,055,000
Power Required (centrifuge plant only), kw	840	210	88	250	470	470
Operating Work Force						
Centrifuge Plant						
Technical	32	13	10	10	7	7
Total	821	270	118	100	45	33
Feed Plant						
Technical	4	6	6	6	5	5
Total	40	33	29	29	27	27
Metals Plant						
Technical	2	2	2	2	2	2
Total	6	6	6	6	6	6
Total Plant Work Force	867	309	155	135	78	66

Centrifuge Model Identification

**DELETED**

TABLE 3

CAS CENTRIFUGE PLANT SUMMARY FOR CLASS Y NATION,  
 50 kg U PER YEAR AT 90% U-235

	Machine Type					
	A	C	G	J	K	L
Capital Investment, \$						
Centrifuge Plant	125,566,000	34,108,000	13,936,000	15,278,000	5,875,000	5,100,000
Feed Plant	3,268,000	2,594,000	2,314,000	2,314,000	2,244,000	2,244,000
Metals Plant	439,000	439,000	439,000	439,000	439,000	439,000
Total	129,173,000	37,141,000	16,709,000	18,031,000	8,558,000	7,900,000
Peak Construction Work Force						
Total Number of Men	1,710	1,040	540	450	330	100
Technical	120	80	40	40	30	10
Construction Manpower, Man-Months	51,080	13,680	6,330	5,870	4,070	3,200
Over-all Construction Time, yr	6.7	3.6	3.3	3.1	3.1	3.1
Operating Cost, \$/yr						
Centrifuge Plant	11,598,000	3,654,000	1,567,000	1,528,000	566,000	433,000
Feed Plant	651,000	521,000	450,000	450,000	430,000	430,000
Metals Plant	161,000	161,000	161,000	161,000	161,000	161,000
Total	12,410,000	4,336,000	2,178,000	2,139,000	1,157,000	1,024,000
Power Required (centrifuge plant only), kw	8410	2110	888	2520	670	470
Operating Work Force						
Centrifuge Plant						
Technical	39	16	12	12	9	3
Total	990	306	142	121	54	10
Feed Plant						
Technical	10	8	8	8	6	7
Total	49	40	34	34	33	33
Metals Plant						
Technical	2	2	2	2	2	2
Total	8	8	8	8	8	8
Total Plant Work Force	1,047	374	184	163	75	81

Centrifuge Model Identification

**DELETED**

619  
202

TABLE 4

GAS CENTRIFUGE PLANT SUMMARY FOR CLASS 2 NATION,  
50 Kg U PER YEAR AT 90% U-235

	Machine Type					
	A	C	G	I	K	L
Capital Investment, \$						
Centrifuge Plant	147,231,000	59,993,000	16,364,000	17,914,000	6,889,000	6,110,000
Feed Plant	3,715,000	3,042,000	2,713,000	2,713,000	2,631,000	2,642,000
Metals Plant	514,000	514,000	514,000	514,000	514,000	514,000
Total	151,460,000	63,549,000	19,591,000	21,141,000	10,034,000	9,166,000
Plant Construction Work Force						
Total Number of Men	2,000	1,210	630	530	220	200
Technical	140	90	45	40	35	30
Construction Manpower, man-months	70,550	21,040	10,040	9,050	6,410	5,700
Over-all Construction time, yr	8.8	4.8	4.3	4.1	4.1	3.1
Operating Cost, \$/yr						
Centrifuge Plant	11,970,000	3,771,000	1,617,000	1,571,000	585,000	471,000
Feed Plant	672,000	538,000	464,000	464,000	446,000	442,000
Metals Plant	166,000	166,000	166,000	166,000	166,000	166,000
Total	12,808,000	4,475,000	2,247,000	2,201,000	1,197,000	1,079,000
Power Required (centrifuge plant only), kw	810	210	88	220	40	30
Operating Work Force						
Centrifuge Plant						
Technical	45	19	14	14	10	10
Total	1,161	382	167	140	64	67
Feed Plant						
Technical	12	9	9	9	7	7
Total	57	47	40	40	32	33
Metals Plant						
Technical	2	2	2	2	2	2
Total	9	4	9	9	9	7
Total Plant Work Force	1,227	438	216	180	112	107

Centrifuge Model Identification

DELETED

V  
10/10

TABLE 5

GAS CENTRIFUGE PLANT SUMMARY FOR CLASS X NATION,  
500 Kg U PER YEAR AT 90% U-235

	Machine Type				
	C	G	I	K	L
Capital Investment, \$					
Centrifuge Plant	255,665,000	96,782,000	105,827,000	56,973,000	33,336,000
Feed Plant	4,466,000	3,869,000	3,941,000	3,448,000	5,377,000
Metals Plant	518,000	518,000	518,000	518,000	518,000
Total	260,649,000	101,169,000	110,286,000	60,939,000	39,231,000
Peak Construction Work Force					
Total Number of Men	1,160	1,490	1,490	1,240	940
Technical	150	100	90	65	70
Construction Manpower, Man-Months	64,120	24,070	23,860	10,770	8,670
Over-all Construction Time, yr	8.6	3.1	3.1	2.3	2.1
Operating Cost, \$/yr					
Centrifuge Plant	21,262,000	8,626,000	3,399,000	5,322,000	2,547,000
Feed Plant	1,035,000	903,000	919,000	810,000	197,000
Metals Plant	566,000	566,000	566,000	566,000	566,000
Total	22,863,000	10,095,000	4,884,000	6,698,000	3,310,000
Power Required (centrifuge plant only), kw	21,250	8900	25,200	4870	1,110
Operating Work Force					
Centrifuge Plant					
Technical	58	26	29	13	10
Total	1,541	630	718	249	122
Feed Plant					
Technical	10	10	10	10	10
Total	79	53	53	30	42
Metals Plant					
Technical	3	3	3	3	3
Total	16	16	16	16	16
Total Plant Work Force	1,616	701	787	325	211

Centrifuge Model Identification

DELETED

TABLE 6  
GAS CENTRIFUGE PLANT SUMMARY FOR CLASS Y NATION,  
500 kg U PER YEAR AT 90% U-235

	Machine Type				
	C	D	I	K	L
Capital Investment, \$					
Centrifuge Plant	308,449,000	116,763,000	127,675,000	44,606,000	40,213,000
Feed Plant	5,389,000	4,667,000	4,754,000	4,100,000	4,086,000
Metals Plant	625,000	625,000	625,000	625,000	625,000
Total	314,463,000	122,055,000	133,054,000	49,331,000	44,924,000
Peak Construction Work Force					
Total Number of Men	1,880	1,790	1,800	1,500	1,190
Technical	160	120	110	80	70
Construction Manpower, Man-Months	106,360	39,930	37,930	17,870	14,570
Over-all Construction Time, yr	12.0	4.3	4.2	3.4	3.3
Operating Cost, \$/yr					
Centrifuge Plant	22,204,000	9,040,000	5,562,000	3,480,000	2,643,000
Feed Plant	1,084,000	946,000	963,000	849,000	875,000
Metals Plant	593,000	593,000	593,000	593,000	593,000
Total	23,881,000	10,579,000	7,118,000	4,922,000	4,111,000
Power Required (centrifuge plant only), kw	21,250	8900	25,200	4070	191
Operating Work Force					
Centrifuge Plant					
Technical	70	32	34	16	12
Total	1859	770	867	300	219
Feed Plant					
Technical	12	12	12	12	12
Total	71	64	64	60	59
Metals Plant					
Technical	3	3	3	3	3
Total	19	19	19	19	19
Total Plant Work Force	1,949	853	950	379	297

Centrifuge Model Identification

**DELETED**

DOE  
6.20.02

TABLE 7

U.S. CENTRIFUGAL PLANT SUMMARY FOR CLASS Z NATION,  
570 Kg U PER YEAR AT 90% U-235

	Machine Type				
	C	O	I	K	L
Capital Investment, \$					
Centrifuge Plant	561,007,000	156,909,000	149,704,000	52,512,000	47,116,000
Feed Plant	6,518,000	5,473,000	5,474,000	4,878,000	4,121,000
Metals Plant	735,000	733,000	733,000	733,000	733,000
Total	568,250,000	163,115,000	155,911,000	57,923,000	52,570,000
Construction Work Force					
Total Number of Men	2,200	2,100	2,110	1,760	1,400
Technical	180	140	130	90	80
Construction Manpower, Man-Months	163,570	61,400	58,330	27,480	21,000
Over-all Construction Time, yr	15.8	5.7	5.6	4.5	3.3
Operating Cost, \$/yr					
Centrifuge Plant	23,000,000	9,531,000	3,676,000	3,592,000	2,773,000
Feed Plant	1,119,000	977,000	994,000	876,000	824,000
Metals Plant	612,000	612,000	612,000	612,000	612,000
Total	24,731,000	10,920,000	5,282,000	5,080,000	4,209,000
Power Required (centrifuge plant only), kw	21,250	8900	25,200	4870	410
Operating Work Force					
Centrifuge Plant					
Technical	82	37	40	19	14
Total	2,180	903	1,016	752	59
Feed Plant					
Technical	14	14	14	14	14
Total	84	75	75	70	62
Metals Plant					
Technical	4	4	4	4	4
Total	22	22	22	22	22
Total Plant Work Force	2,285	1,000	1,113	444	308

Centrifuge Model Identification

**DELETED**

679  
777

TABLE 8

## MINIMUM TIME REQUIRED TO PRODUCE FIRST NUCLEAR WEAPON

Assumptions	Time Required, years			
	Class Country			US
	X	Y	Z	
(1) Knowledge of model C details				
(2) No knowledge of model C details				
(3) Knowledge of models K and L details after they are developed**				

**DELETED**

\* Without details or considerable assistance from another country having details of the centrifuge model, this class country would probably not develop the model on its own.

PLANT DESCRIPTION

CENTRIFUGE FACILITY

Estimates of the capital investment, operating costs, construction schedule, construction manpower, and operating manpower requirements for each of the three processes of the centrifuge production facility are presented in Tables 9 through 25, based on estimated US costs. Plants having production rates of 50 and 500 kg uranium per year of highly enriched U-235 were investigated. The 50 kg uranium per year product rate was chosen to reflect the production of at least one nuclear weapon per year. The 500 kg of uranium per year product rate is approximately the largest production rate for which the centrifuge plant might present attractive advantages over a gaseous diffusion plant. Six basic centrifuge models were studied for each of the above production rates.

Centrifuge Models

The details of the six centrifuge models studied are presented in Table 1; the centrifuges can be grouped into the following three categories:

Present Machines. These are centrifuges which have already been built and tested. Although, in all cases, there does not exist as much experimental and operational data as would be desirable for the design and construction of a centrifuge plant using these machines, the separation performance of the machines is essentially known. Fabrication of a large number of machines of the types in this group could be started almost immediately by the United States. Two machines are included in this group. These are:

ZIPPE CENTRIFUGE

Zippe 3-in., 350 m/sec subcritical centrifuge with a separative work of 0.34 kg U/yr. This centrifuge model is included in the study since considerable information and reference is made to this centrifuge in the unclassified literature. It is not felt that anyone would actually attempt to build a facility to produce highly enriched uranium using this centrifuge because of the high capital and operating costs and the large number of centrifuges required.

DOE  
6.2(e)

**DELETED**

The original Zippe centrifuge, as constructed at the University of Virginia, consisted of a 3-in.-dia extruded rotor which was rotated at a peripheral speed of 350 m/sec. A schematic of the Zippe centrifuge is shown in Figure 1. The rotor was prepared from extruded 7075-T6, 0.040-in.-thick aluminum



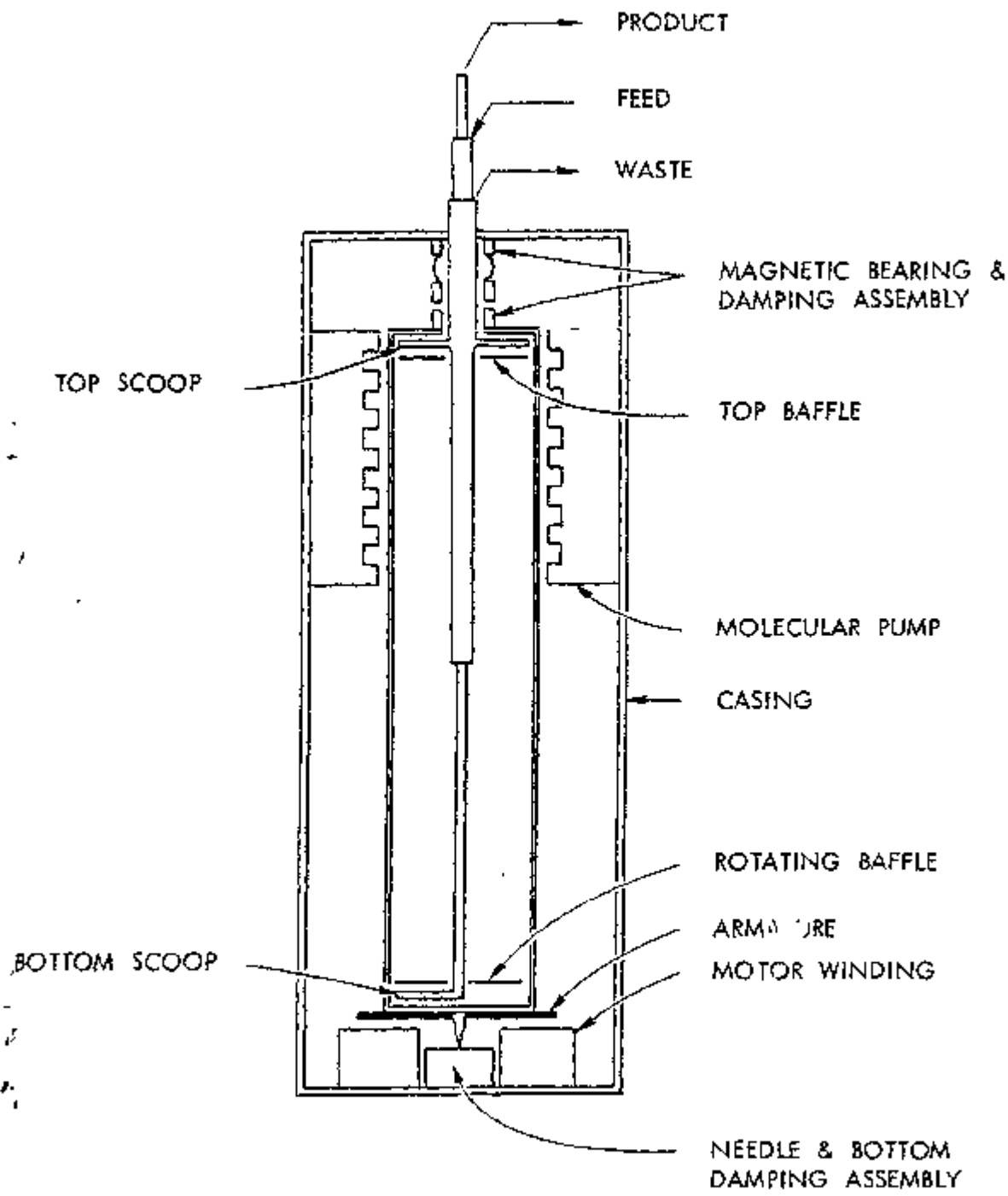

Figure 1  
SCHEMATIC REPRESENTATION OF TYPICAL ZIPPE CENTRIFUGE

alloy, was threaded at the ends and equipped with threaded aluminum end caps. The bottom bearing and needle assembly and top magnetic bearing were similar in principle to those used in the current subcritical machine. The top and bottom damping systems were not as refined as in current models, but operated with similar objectives. The rotor was driven with an axial air gap rotor where the armature was a simple steel disk attached to the bottom of the centrifuge rotor. A stationary scoop system was inserted in the center of the rotor for gas feed and gas removal purposes. While models of this machine were successfully produced at ORGDP, and a number of units were operated in the experimental centrifuge cascade over a considerable period of time, the characteristics of this centrifuge never were considered to be wholly attractive for cascading purposes, owing to such factors as high inventory loss and non-reproducible separative performance. For purposes of comparison, however, the Zippe centrifuge will be considered here as a base point in the evaluation of the centrifuge process. The Zippe centrifuges produced for experimental testing at ORGDP and those tested by Zippe and personnel at the University of Virginia had separative capacities in the range of 0.34 kg U/yr!

**DELETED**

PRESENT 6-INCH SUBCRITICAL CENTRIFUGE

~~SECRET~~

12.71  
62.7

12.71  
6.27

DOE  
6.2(a)

**DELETED**

Proposed Machines. These are centrifuges for which the separation performance has not yet been extensively measured experimentally. In both cases some mechanical tests on the model have already been made. These centrifuges are the logical descendants of the group 1 machines. It is felt that there are no major obstacles in the path of the development of these machines, and that sufficient information has been obtained on their forerunners to permit the prediction of their performance with reasonable accuracy. The development and testing of these machines required to bring them to a production capability in the United States would be anticipated to be in the neighborhood of one to three years.

PROPOSED SUBCRITICAL CENTRIFUGE

**DELETED**

be achieved either with a circulating coolant system or an evaporative cooling system using the atmosphere as a heat sink.

cooling may

**DELETED**

proposed subcritical centrifuge is shown in Figure 2.

A schematic of this

PROPOSED SUPERCRITICAL CENTRIFUGE

**DELETED**

A schematic of this proposed supercritical centrifuge is shown in Figure 3. The unit will be driven from the closed end of the bowl by a direct coupling with a conventional squirrel-cage induction motor.

**DELETED**

W  
6.1

W  
6.1

W  
6.1

DOE  
6.2(a)

DOE  
6.2(a)

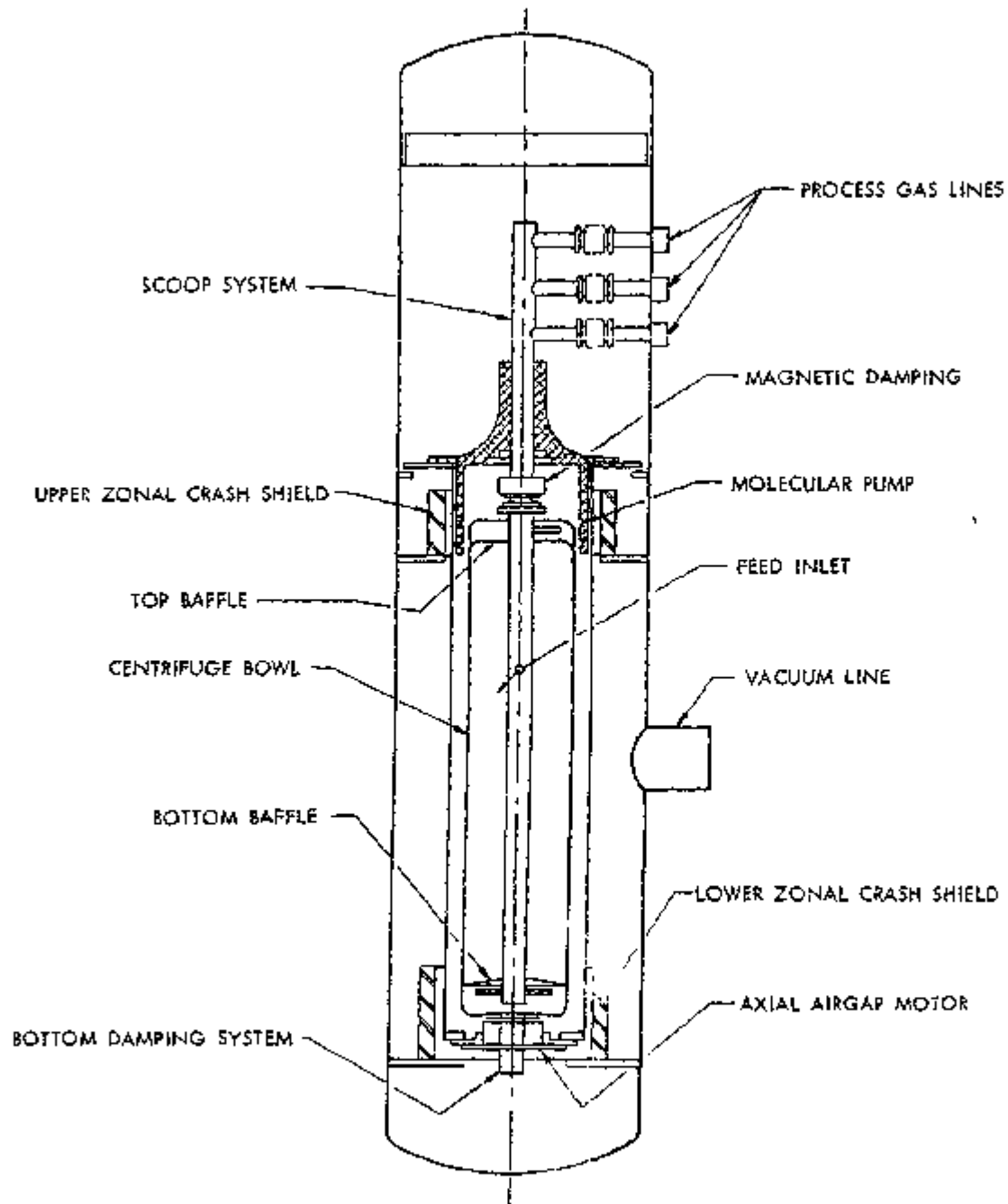

Figure 2  
SCHEMATIC REPRESENTATION OF THE PROPOSED  
SUBCRITICAL CENTRIFUGE

**DELETED**

ce  
part

DST  
622

**DELETED**

A magnetic bearing is employed at the open end of the rotor. A servo-system which will automatically maintain the appropriate gap between the rotating and nonrotating magnetic portions of the bearing will be used to regulate the magnet gap spacing. A conventional Zippe-type gas extraction system will be incorporated in this machine, being supported from an assembly located at the open end of the rotor.

**DELETED**

Owing to the greater length of the rotor and higher peripheral speeds, greater separative capacities will be available through the use of this unit.

**DELETED**

Future Centrifuges. The development of these machines is dependent upon appreciable advances in technology and it would be expected to require 5 to 10 years before these machines would be ready for plant installation. Two machines are included in this group. They are:

~~\_\_\_\_\_~~

At this time there appears to be no basic limitation on the diameter of subcritical machines; the optimum size will be established by economic considerations relating to the cost of building such machines, their operating costs, and their separative capacities. Research currently being conducted by the various glass filament manufacturers seems likely of developing higher strength glasses. Moreover, winding techniques undoubtedly will be developed to utilize higher fractions of the available strength of the glass filaments in the centrifuge rotor.

**DELETED**

6.2(a)

not appear unreasonable that such a machine would be available with five to ten years of development effort.

DOE  
6271

**DELETED**

### CENTRIFUGE PLANT CHARACTERISTICS

The centrifuge is characterized as a high-enrichment, low-throughput device. In a plant design the centrifuges are connected in parallel to obtain the desired throughput, and these parallel connected banks of centrifuges are then connected in series to obtain the desired over-all enrichment. The tails concentration, that is the degree of stripping, would depend upon many factors such as the cost of feed, equipment costs, operating costs, etc. An estimate was made of the amount of stripping which would probably be attractive with the various centrifuge models, and the tails concentration associated with this stripping is indicated in the Tables of Centrifuge Costs, 9 through 19. The amount of stripping varied from very little (tails concentration 0.0065) for the Zippe model to a considerable amount (tails concentration 0.0041) for the future supercritical centrifuges operating in the larger plants. Ideal plant tapers for those plants studied here are shown in Figures 9 through 14. These figures show the number of centrifuges in parallel for each stage of the plant along with the number of stages (length) required.

In describing a centrifuge cascade for the production of U-235, it is probably best to discuss at length the individual factors which are involved in the layout and design of the plant. The following paragraphs will describe the main items of interest.

#### PLANT LAYOUT

In order to reduce capital, operating, and maintenance charges, the centrifuges in a production plant will be piped and wired so that vacuum, electrical, instrumentation, and control equipment can be shared by a number of machines. The smallest grouping of machines will be referred to as a "cell." A description of a typical centrifuge cell follows.

#### Centrifuge Cell

There will probably be two types of cells in the centrifuge plant, one will be the "parallel cell," the other the "series cell," The two cell types are described below.

~~SECRET~~

~~TOP SECRET~~

Parallel Cell. A group of centrifuges operating in parallel\* valved, wired, and instrumented so that the entire cell of machines must be started, operated, and stopped as a unit. The cell would be the smallest grouping of machines which could be isolated from the cascade. A schematic of one-half of a ten-machine parallel cell is shown in Figure 4. A complete ten-machine parallel cell layout is shown in Figure 5. As shown in Figures 4 and 5, the ten machines share common vacuum and process piping. The cell vacuum piping can be isolated from the larger vacuum system by the automatic block valves shown,

**DELETED**

The volume of the parallel cells is estimated to be sufficiently large that failure of a single machine will not release sufficient gaseous inventory to cause damage to adjacent operating centrifuges. It is assumed that the supercritical machine will also be capable of tolerating modest pressure excursions. After a cell has been initially evacuated and is ready to be placed on stream, the vacuum valve is closed, thus isolating the cell from the main vacuum system. The process valves are opened in appropriate sequence and the machines placed on stream. The pumping action of the rotating centrifuge bowl will tend to preserve the initial vacuum conditions. Should one of the machines in this cell develop trouble, the appropriate alarm would be given in the control room and the process block valves would close, isolating the cell from the cascade and minimizing the loss of process inventory. If this particular cell was being used as a purge station, the vacuum block valve would remain open during normal operation and would be automatically closed in the event of trouble.

Series Cell. A group of centrifuges operating in series, valved, wired, and instrumented so that the entire cell must be started, operated, and stopped as a unit. The difference between the parallel and series cells is that the parallel cells contain centrifuges all operating in the same cascade stage at the same gas concentration while the series cells contain stages\*\* of centrifuges each handling a higher concentration than the centrifuge stage below. A schematic of a ten-machine series

---

\* Centrifuges operating in the same cascade stage, each being fed gas of the same concentration and each producing upflow and downflow streams of the same concentration.

\*\* A stage in a centrifuge plant would consist of centrifuges all operating at the same concentration level. At the feed point of a large centrifuge plant the feed stage could consist of hundreds of centrifuges operating in parallel, while at the product point of a small plant the product stage might consist of a single centrifuge.



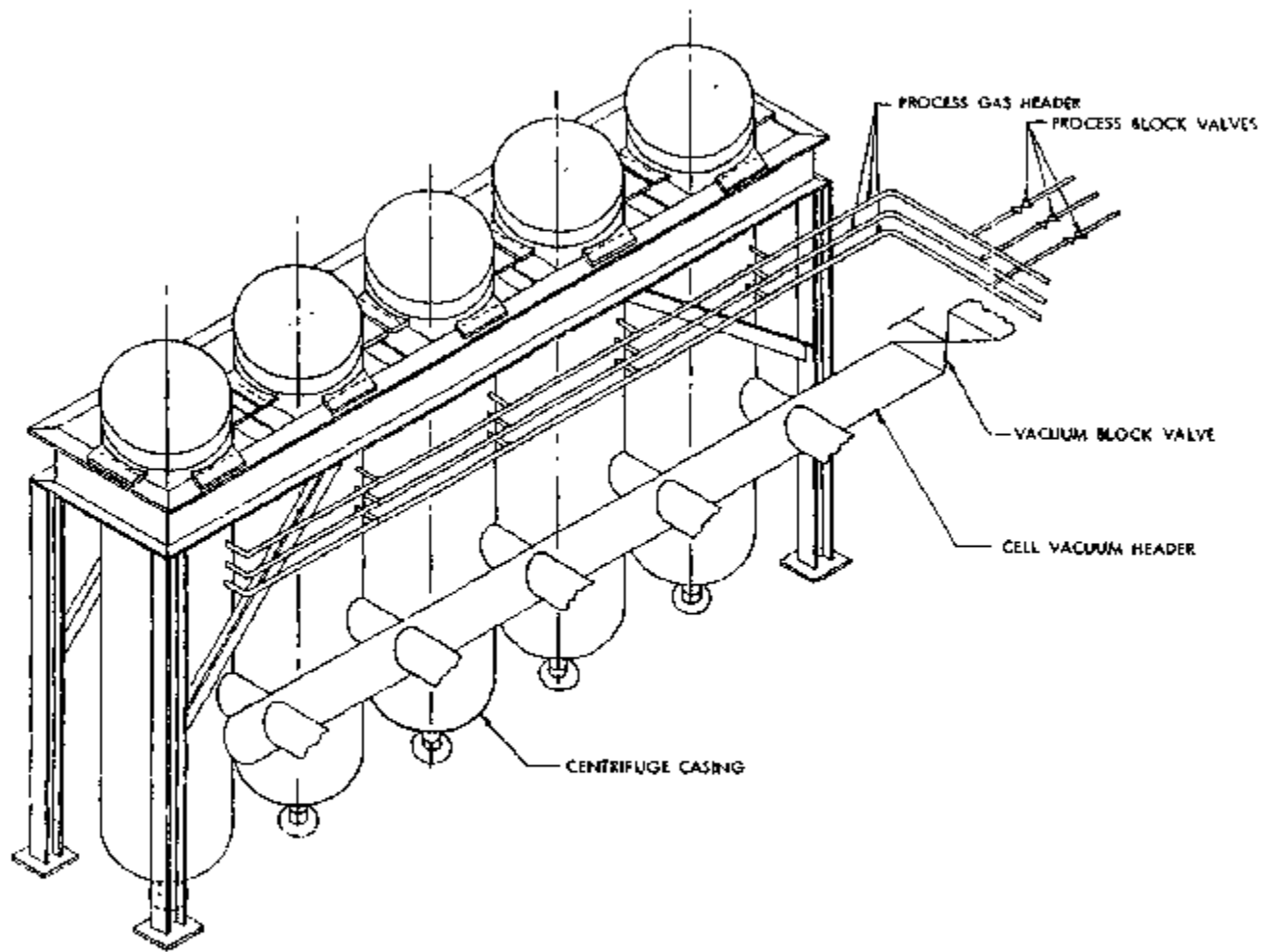

Figure 4  
ONE-HALF OF A 10-CENTRIFUGE PARALLEL CELL

~~SECRET~~

SECRET

~~SECRET~~

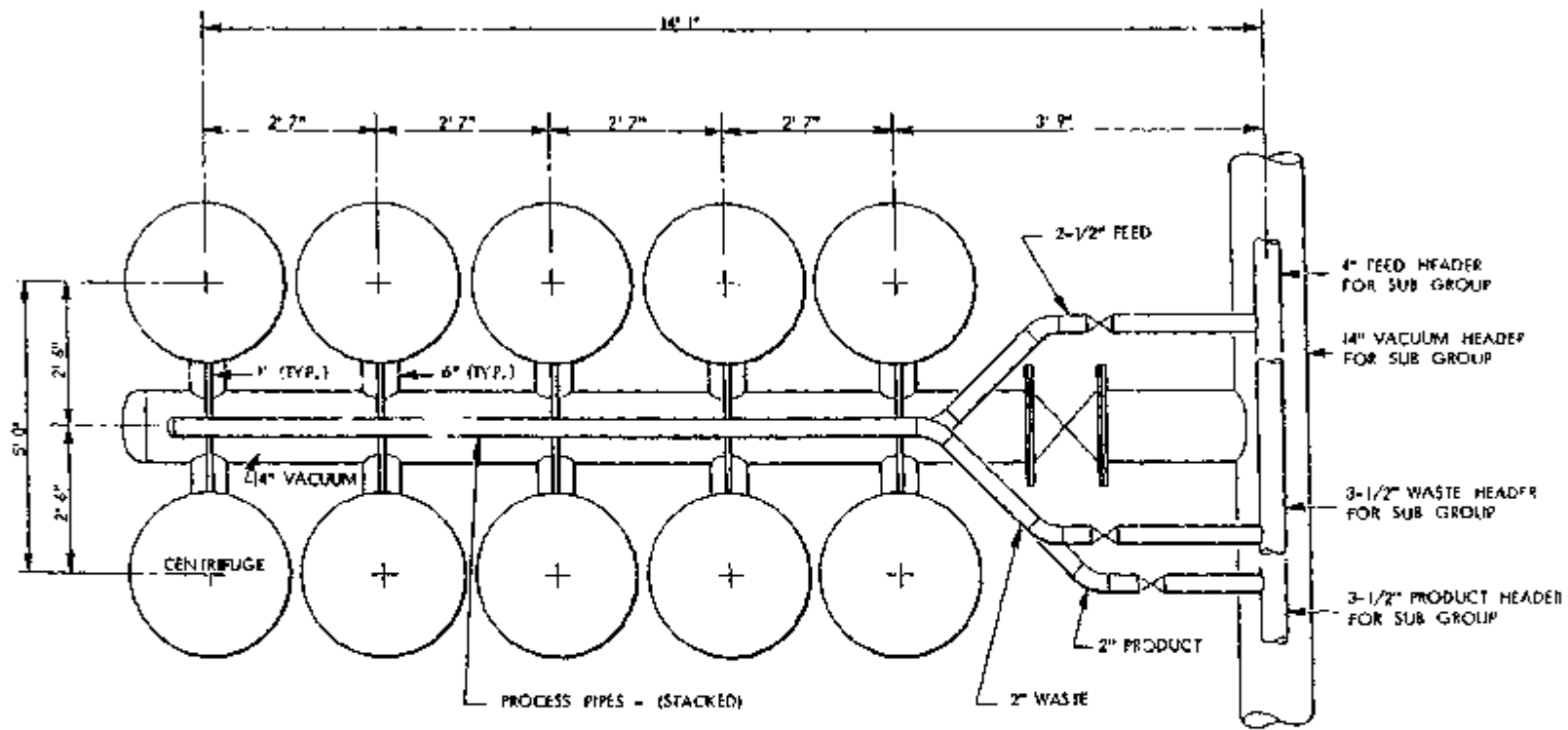

Figure 5  
10-CENTRIFUGE PARALLEL CELL

cell containing one centrifuge per stage is shown in Figure 6. The ten machines share a common vacuum piping, but each machine has individual process piping in that it receives feed from both the machines above and below it in the cell and sends a product stream to the centrifuges above and a waste stream to the centrifuges below. It may be necessary to have small, automatic block valves in the process lines connecting stages in the series cells to avoid a buildup of light gases in the top stages when the series cell is isolated from the cascade. The buildup of light gases could cause excessive pressures which might lead to the destruction of the centrifuge. For the economic evaluation presented in this report, these block valves were not included, but should they be needed the effect on the unit cost of separative work would be very small. Each stage of machines has a flow metering device on one of the exit process streams. The machines share a common process control valve at the top and bottom of the cell, which establishes the desired flows into and out of the cell. The vacuum system can be isolated from the pumping system by use of the automatic block valve shown. The process system can be isolated from the cascade by the automatic block valves at the top and bottom of the cell. When a series cell is isolated from the cascade the cascade is either split at that point or the cell is by-passed, hence, the valves and piping necessary for both of these operations are required.

In order to obtain additional economies, groups of parallel cells will probably be piped and instrumented to share a common vacuum, instrumentation, and process control system wherever possible. Such a grouping of parallel cells will be called a sub-group. Series cells, because of the concentration range spanned in the cell, and the necessity to minimize mixing of assay when trouble arises, probably will not be grouped into sub-groups. A description of a typical sub-group follows.

Sub-groups. Groups of parallel cells operating in parallel, which share a common vacuum and process control system. Figure 7 shows a schematic of a sub-group which contains ten parallel cells. The sub-group has a common vacuum system consisting of an appropriate size diffusion pump, cold trap and a rough pump, vacuum valves, and a properly sized vacuum header. The sub-group also has a common flow control system which regulates the feed, product and waste flow out of the sub-group process headers. Each cell, as shown earlier, can be isolated from the vacuum and process piping of the rest of the sub-group. Each sub-group in turn can be isolated from the process system of the rest of the cascade stage and the flow by-passed by the three process block valves shown at the end of the sub-group in Figure 7.

The number of centrifuges connected in a cell and the number of cells connected in a sub-group will depend upon many factors such as machine reliability, cost of vacuum pumps, cost of vacuum and process hardware, separation factor of the individual centrifuge, etc. The larger the cell and sub-group the greater the capital savings, but the larger the losses in separative work will be when a centrifuge or an auxiliary system gives trouble requiring the shut down of a cell or sub-group.

**DELETED**

6.2 (a)

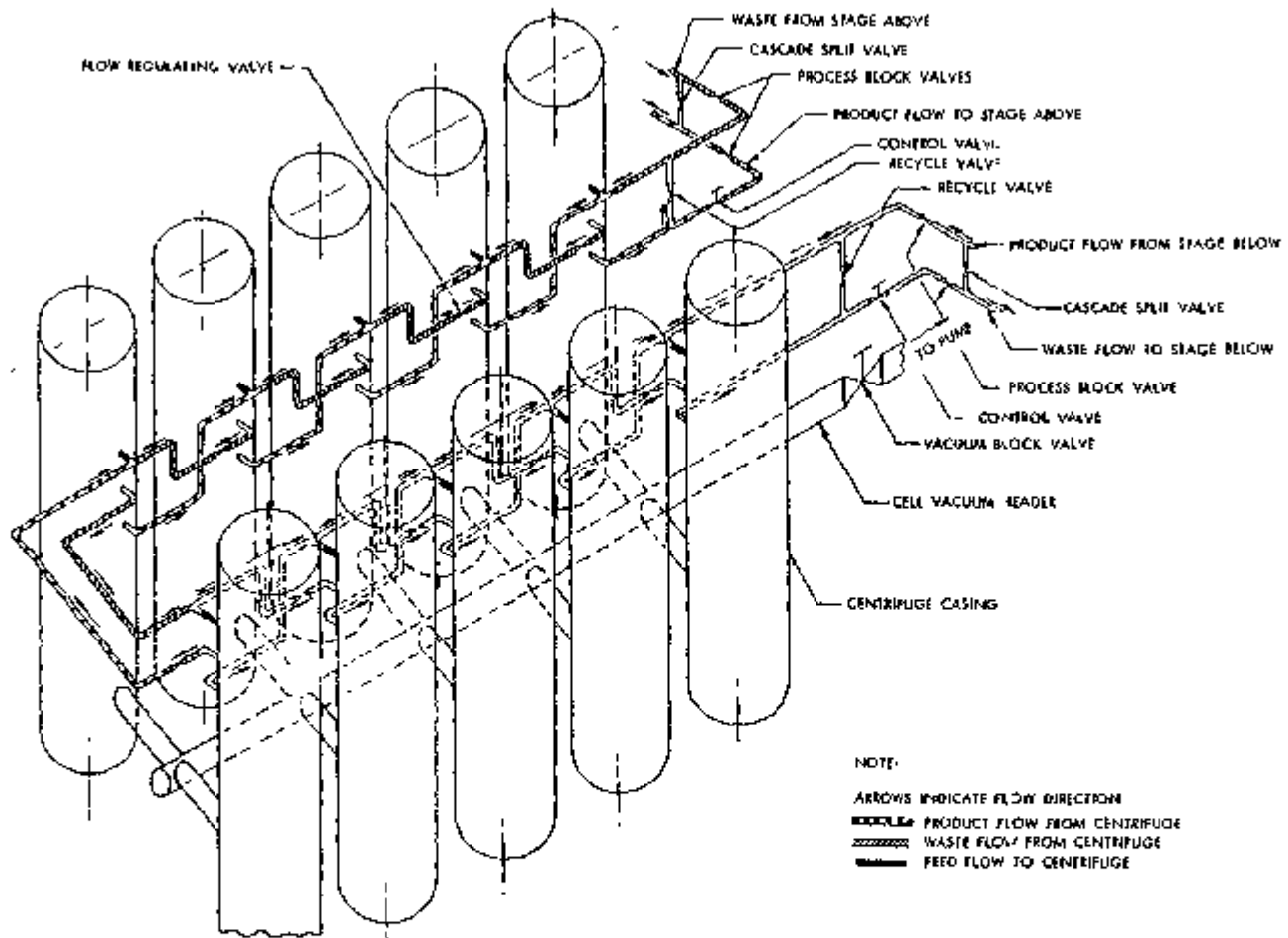
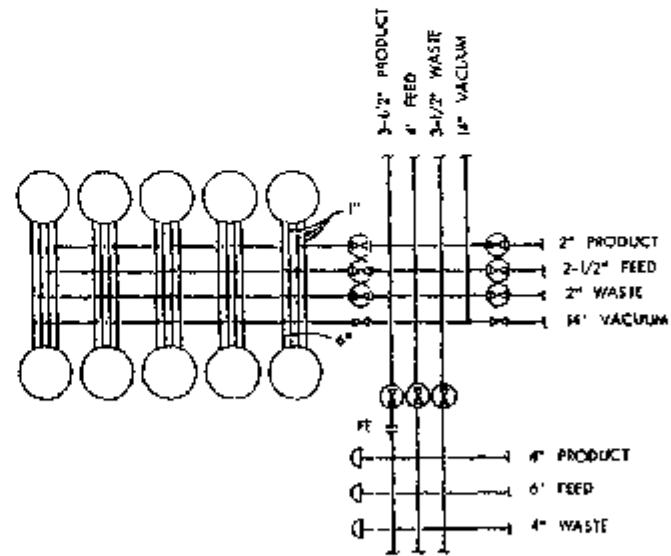
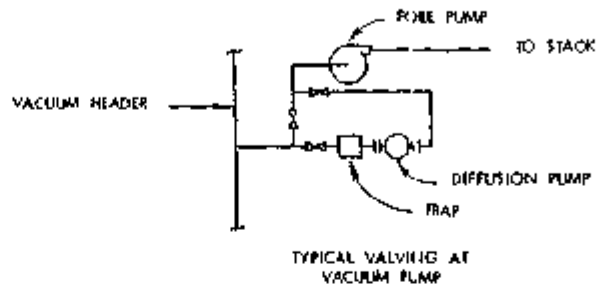
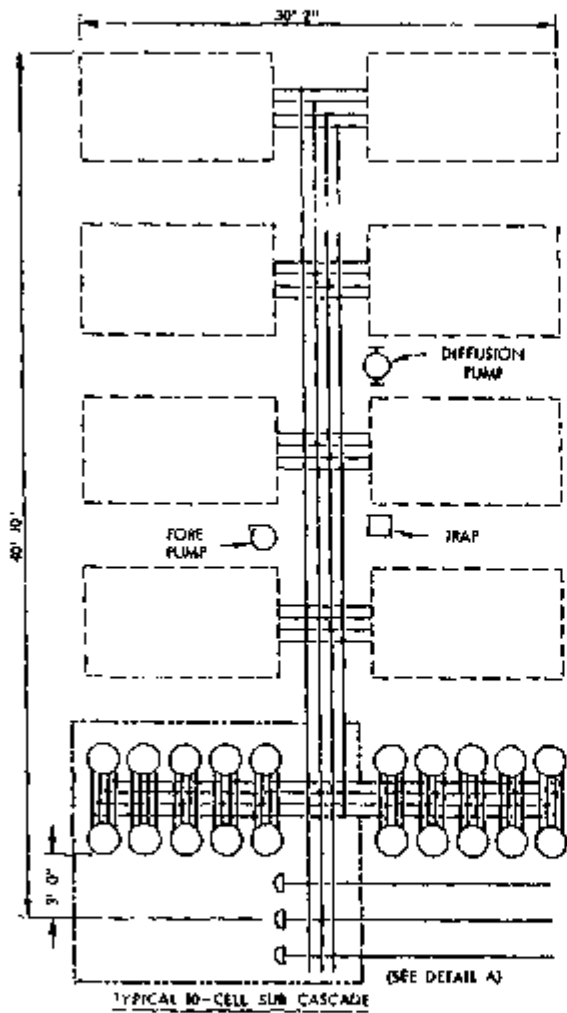

Figure 6.  
10-CENTRIFUGE SERIES CELL  
(ONE CENTRIFUGE PER STAGE)



DETAIL A: TYPICAL PIPING & VALVING AT POINT WHERE THE SUB GROUP PIPING TIES INTO STAGE PIPING

Figure 7  
TYPICAL 10-CELL SUB CASCADE

DOE  
6.2(u)

**DELETED**

These reliability predictions were coupled with preliminary cost estimates for various cell and sub-group layouts to arrive at a reasonable economic cell and sub-group size. A reasonable first estimate of cell size would be about ten machines for the parallel cells and anywhere from a few up to ten stages for the series cells depending upon the number of centrifuges per stage and the separation factor of the individual centrifuges. At the feed point of very large plants where many hundreds of centrifuges must be operated in parallel to supply the large interstage flow requirements of the feed stage, sub-groups in the range of ten parallel cells (i.e., 100 centrifuges) seem reasonable. For smaller plants and for stages far removed from the feed point where the interstage flow rates are lower, smaller sub-group sizes will be desirable. The use of series cells will be desirable as the product or waste point is approached since, in these locations, few machines in parallel are required to supply the necessary interstage flow rates.

**ELECTRICAL EQUIPMENT**

Process Electrical Equipment

Motor Drive System. The centrifuges will be driven from a high frequency power system supplied by alternators. The machines must be started and brought to operating speed from a lower frequency start-up system to minimize overheating during start-up. In the plant, the electrical drive systems will be divided into appropriate size units where each unit will contain the necessary drive alternators (including spares) and the necessary start-up equipment for a block of centrifuges. The number of sub-groups included in the block will depend upon the plant size, power required, number of machines operating in parallel, etc. The size and number of alternators required for an electrical unit will vary with plant size and stage size. A typical high frequency electrical distribution system is illustrated in Figure 8. Figure 8 also shows the electrical distribution system for the auxiliary equipment, lighting, etc.

Centrifuge Motors. Each centrifuge will be driven by its own individual motor which, in the case of the subcritical machines, will probably be a hysteresis-synchronous axial air gap motor with the rotor consisting of a steel disk attached to the bottom of the centrifuge bowl. In the case of the supercritical machines, the motors presently envisioned will be a conventional squirrel cage induction motor coupled to the centrifuge bowl by means of a drive shaft.

Distribution System. The alternators will be connected to busses to equalize loading with spare alternators being available to take up the load should one of the alternators fail. The power busses will be connected to the individual sub-group control panels which will serve as feeder stations for the individual centrifuges. Each centrifuge will be supplied with an ammeter and fusing protection for the motor.

Switchyard. Above certain size electrical loads, it will become necessary to provide switchyards to step down the voltage from the power distribution network. In order to have a reliable power supply, the switchyards should be double ended.

DOE  
E.O. 12958

**DELETED**

Protective System. The high frequency power supply will probably have the following protective equipment. A light to indicate that a motor fuse has burned out, an overload protection for the alternator which will cut out the alternator if the current gets too high, a power failure alarm.

#### Auxiliary Power Supply

It will be necessary to supply power and distribution networks for the vacuum pumps, instrumentation, isolation valves, lighting, crane operations, welding machines, power tools, etc. The costs of the over-all electrical system will depend upon the size of the plant, the power requirements of the individual centrifuges, and the arrangement of centrifuges in the cascade. For supercritical machines a positive source of power must be available to actuate the drive bearing constraint and to vary the magnet gap controller, since means are needed to permit safe deceleration in the event of a general power failure. A source of DC provided from storage batteries appears satisfactory for this purpose.

#### PROCESS PIPING

The process piping to each centrifuge will consist of a feed line, a product line, and a waste line. The line sizes to the individual machines will be quite small and will probably not exceed about 1-in.-dia. The lines from individual machines in the parallel cells will tie into header lines for the cell which will in turn tie into headers for the sub-groups which will tie into headers for the stage. The process lines in general will be fairly small, probably not exceeding 12-in.-dia for the largest piping inter-connecting sub-groups or stages. By-pass piping and valving, isolation valving, and control valving will be required for each cell and sub-group. While the pipe sizes will, in general, be quite small, the vacuum requirements will be stringent and careful assembly and extensive leak testing will be required. A flexible coupling to tie the actual centrifuge scoop system to the process piping will probably be required to allow easy installation and removal of the centrifuges. The process piping will probably be Ni-plated steel to assure low consumption and freedom from corrosion products which could plug scoop lines and cause other troubles with the centrifuge operation. The piping must be sized so as to keep the pressure drops very low, since the available pressure from the scoop systems is low and it is necessary to keep the feed pressure quite uniform on all the centrifuges in a stage to assure uniform feeding to the individual centrifuges.

#### PROCESS CONTROLS

It will be necessary to control the process flow rates in order to assure optimum and stable plant operation. It also will be necessary to monitor the speed and temperature of the centrifuge bowl and the vacuum jacket pressure in order to assure safe, constant performance from the centrifuge. In a large centrifuge plant, due to the very large number of centrifuges required, the design criteria which must be adopted for the control and instrumentation systems are those of minimizing the actual operating information obtained and recorded for individual machines which are performing satisfactorily. Since the temperature and speed of the centrifuge bowl and



the pressure of the vacuum jacket are not controlled in the usual sense, it is desirable to adopt a supervisory type of control for these variables. This supervisory control would initiate protective or corrective action only if certain safe limits are exceeded. Thus, the variables of speed and temperature need only be scanned routinely and if the values are within control limits, there is no need to record the actual values. When deviations from acceptable limits do occur, it is only necessary that suitable alarms be activated. An increase in vacuum jacket pressure above a given level will be interpreted as a machine failure and the necessary instrumentation, alarms, and recording equipment must be available to immediately detect trouble, sound alarms, and isolate equipment. Equipment must also be available to measure and record the centrifuge bowl speed and temperature for trouble shooting individual machines when they exhibit troubles or when a cell of machines is being started or stopped and it is necessary to observe carefully the machine operating conditions. This use of supervisory control will permit important savings in instrument costs and also in operating costs since it results in a central control room equipped with simple alarm instruments which require little maintenance, are reliable, and easy to interpret.

#### Process Gas Controls

The centrifuges will be fed by a single feed tube at the approximate center of the bowl. A scoop system will remove the product and waste stream from the bowl through individual lines. The individual centrifuge feed, product, and waste tubes must be designed and manufactured so that they present uniform flow restrictions to the process gas and thereby act as flow regulating devices assuring uniform and predictable flow into and out of each machine in a given cell. A control valve will be needed between the product header of a sub-group and the product header for the stage to control the fore pressure of a critical metering orifice. The control valve will be operated and controlled pneumatically to regulate the product flow from the sub-group. This will control the cut of the sub-group and provide a means of damping pressure disturbances in the cascade. A manual valve will be needed in the waste header of a sub-group to maintain inventory levels in the sub-group at desired levels. Once this valve is set for a particular steady state operation, little additional adjustment is anticipated. Automatic block valves will be available in the feed, waste, and product headers for each cell. In the event a machine fails in the cell, these valves will immediately close and isolate the cell from the cascade. No difficulty is anticipated for the remaining cells as the feed rate will simply be increased typically by 10 - 25% per machine. This, of course, will result in non-optimum machine performance for the period that the cell is off stream but assures continuous plant operation. For the parallel cells and sub-groups, control valves will be used between the waste header of one stage and the feed header of the stage below; and also between the product header of one stage and the feed header of the stage above. For those portions of the plant (i.e., near the product and waste) where the series type cells are used, control valves and metering orifices will be used at both ends of the cell to maintain the desired upflow through the cell. Limited tests performed in the ORGDP 35-machine centrifuge facility have indicated that this type of control system should perform satisfactorily.

### Centrifuge Controls

Speed. The speed of the centrifuge will be controlled in principle by the alternator frequency. The alternators are driven by induction motors which are slip controlled with load and motor size so that the alternator frequency is reasonably constant. Each machine will have a speed pick-up probe and the speed will be automatically monitored on each of the machines of a sub-group every few minutes. The speed will not, however, normally be recorded or indicated, but will be automatically checked against the design speed. If the speed is more than a set amount from design, an alarm will sound in the central control room and indicator lights will be turned on at the cell to indicate the offending cell. The process operator will then check the equipment, locate the offending machine and take the necessary corrective action. The necessary switching and recording equipment will be available to allow switching to any machine in a sub-group and monitoring and recording its speed to locate troubles and to follow the speed during start-up operations.

Bowl Temperature. A thermocouple will be installed on the scoop system to provide an estimate of the bowl temperature. As with the speed, the temperature will be monitored automatically on each machine of a sub-group (or one instrument might handle several sub-groups) every few minutes. The temperature will not be indicated or recorded, but should the temperature of a centrifuge indicate above a pre-set upper limit, an alarm will sound in the control room. The necessary switching and recording equipment will be available to check the temperature of the machines in the offending cell and to permit trouble shooting in order to decide what action to take.

Vacuum Pressure. A sensitive Pirani-type gauge will monitor the pressure in the vacuum header of each cell. Should this pressure exceed a pre-set limit, indicating inleakage or machine failure, an alarm will sound in the control room and the process and vacuum isolation valves will close, isolating the cell from the sub-group process and vacuum system. The cell can then be checked to determine the cause of troubles and appropriate action taken.

### Other Controls

In addition to the above instrumentation, controls and alarms will be needed to handle the failure of power, coolant pumps, vacuum pumps, centrifuge motors, and for isolation and by-pass of sub-groups during periods of troubles.

### PROCESS AUXILIARIES

There are many auxiliary systems needed in the centrifuge plant. The more important are listed and briefly described below.

### Vacuum System

In order for the centrifuge bowls to rotate at the high speed desirable for good separation performance, it is necessary that a good vacuum be maintained

in the volume surrounding the centrifuge bowl (i.e. 0.1 to 1.0  $\mu$  depending upon speed, size, etc.). Properly sized diffusion and rough pumps must be supplied to evacuate the centrifuge jackets so that start-up operations can commence. Once the machines are at operating speed, the centrifugal action of the centrifuge itself tends to maintain the necessary vacuum environment. The vacuum system must be large enough to allow for fairly rapid pump-down of the system to reduce the start-up time, and the system must be tight enough to eliminate problems due to in-leakage of atmospheric gas to the system. The diffusion pumps must be protected by cold traps to remove any process gas which may be in the vacuum system. All vacuum piping will be nickel plated to minimize corrosion and improve the pumping characteristics of the system.

Cooling System

The normal heating due to the inefficiency of the centrifuge motor, and the heating produced by the drag of the scoops and of the molecular pumps necessitate the removal of heat from the centrifuge. Since the centrifuge operates in vacuum, this heat is rather hard to remove

**DELETED**

Box  
6.26

A circulating oil system which will cool the centrifuge motor, bowl, and damping system (and also supply oil for damping in the supercritical machine) is presently being used. The oil is pumped through a water cooler and then returned to the centrifuge. The use of a self contained, evaporative coolant system for the subcritical units is presently in the early design stage. In the evaporative system, the heat at the motor and bowl would be removed by evaporating a low boiling liquid such as ethyl ether. The vapors would be cooled by radiation to the outer centrifuge casing, be condensed, and return to be evaporated again. Such a system would eliminate the external piping, pumping, and water cooling system and as such should be a simpler, more economical system.

Lubricating Oil System

Subcritical Centrifuge. In the subcritical centrifuge the bowl rotates on a very small diameter needle (shaft) which rotates in a hemispherical cup in a hard metal support plate. This simple bearing system is filled with oil at startup, and indications are that it can operate for extended periods (years) with no oil addition or maintenance. Therefore, there is no lubrication system as such for the subcritical machines.

Supercritical Centrifuges. The more elaborate bearing and damping system of the presently proposed supercritical centrifuge requires the use of a high pressure oil system for damping and the removal of a sizeable amount of heat from the damping and drive systems. It is expected that in a plant, the lubricating oil system and the cooling system would be combined in a single system.

### Process Gas Purge System

Experience with operation of the present CRGDP 35-machine cascade has shown that lights will be passed through the cascade by the scoop system. Provisions must be made to remove any in-leakage at various stages in an operating plant to prevent undesirable pressure buildup. The vacuum system, which is installed for start-up of the centrifuges, will also act as the purge system. The volume surrounding the centrifuge bowl below the molecular pump (which will keep most of the heavy  $UF_6$  out of this volume) can be pumped when needed with the existing vacuum equipment during operation to remove the lights from the system. The volume of the vacuum system of each sub-group is sufficiently large that the rise in pressure due to the failure of a single machine will not cause damage to the other machines in purge cells connected to a common vacuum system; nor would the resultant pressure surge overtax the vacuum equipment.

### Process Gas Feed, Waste, and Product System

These could be similar to the present facilities installed in the  $UF_6$  gaseous diffusion plant. Controls, metering equipment, heating facilities, and refrigeration equipment would be required.

### Site Auxiliaries

These items would include roads, parking lots, security provisions, fire protection, maintenance and assembly shops, administration buildings, laboratories, cafeterias, dispensaries, etc. The size, type, and cost of these facilities will depend upon the size and location of the particular plant being designed.

### Process Building

The process buildings would probably be constructed of concrete block. The load levels will be quite small so that a minimum of reinforcing and heavy structural steel will be required. The centrifuges and their utilities would probably be installed in one level, with a gallery above for machine installation and removal operations. The machine casings could be supported by steel frame-works as shown in the partial cell schematic, Figure A-8. Sufficient overhead clearance will be available to allow easy removal of the centrifuges from and installation into their casings. The process buildings will include central control rooms, offices, rest rooms, storage areas, some maintenance facilities, in addition to the centrifuge cascade areas. For the large plants, a total floor area per centrifuge is estimated at approximately 20 square feet. The process buildings would be heated and ventilated as required for the health and comfort of the operators and maintenance force.

## OPERATING COSTS

### Power Costs

The annual power charges for a centrifuge will consist of centrifuge drive power, lighting and maintenance power, and centrifuge auxiliary power.

The centrifuge drive power will consist of the power necessary to drive and control the centrifuge bowl at design speed (power needed to overcome the gas drag friction, bearing load, damping load, etc.). This power will be determined mostly by the centrifuge model (i.e., size, speed, damping characteristics, vacuum system, etc.).

The lighting and maintenance power will represent power necessary to assure adequate lighting for the process building, maintenance areas, assembly areas, and administrative areas. This power will also include the power necessary to carry out the plant maintenance requirements (i.e., welding power, power for cranes and lifts, power tools, etc.). This lighting and maintenance power will depend upon the plant size and the number of centrifuges in the plant cells and sub-groups.

The auxiliary power includes the power required to operate the necessary auxiliary equipment such as vacuum pumps, coolant pumps, refrigeration, etc. The auxiliary power will depend upon the plant size and the number of centrifuges in a cell and sub-group.

### Operating and Maintenance Labor Costs

At this particular stage of the centrifuge development, estimating the required maintenance and number of operators needed for the safe, efficient operation of a gas centrifuge plant is extremely difficult. Estimates obtained now must be taken as very preliminary and subject to change. It is felt that the costs presented here reflect optimistic thinking and future costs are not expected to be lower.

### Material Cost

The cost of worked materials was based on the assumed failure rate, overhaul requirements, and routine maintenance requirements. The estimated cost is not considered very reliable due to the lack of actual operating experience with the centrifuges. This cost for any practical centrifuge plant will probably be low compared to other costs and, therefore, should not have much effect upon the unit costs. A cost of \$40 per machine per year was assumed for the subcritical centrifuges and \$100 per year for the supercritical centrifuges as a minimum cost for a large installation (i.e., 10,000 centrifuges). For smaller installations the costs were scaled based on ORGDP experimental centrifuge cascade experience.

~~TRD~~

FEED PLANT

The amount of stripping performed in the plant will affect the amount of normal assay feed required for a given product rate and concentration. The various centrifuge models and plant sizes considered here require an estimated range in desired feed rate from 17.5 tons per year to 700 tons per year. Because of this wide range in desired feed rate, the costs of construction and operation of feed plants with capacities of 25, 50, 100, and 500 tons per year were estimated and are presented in Tables 20 through 23. The costs for feed plants within this range were obtained by interpolating between the estimated costs, and those slightly outside this range were obtained by extrapolating these estimated costs.

Briefly, the process which would probably be used can be described as follows: The ore concentrate, assaying approximately 60% uranium, is treated with nitric acid, and the uranium is dissolved.

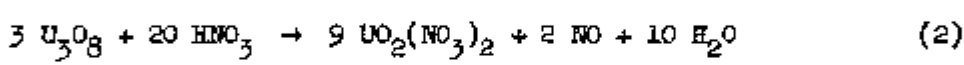
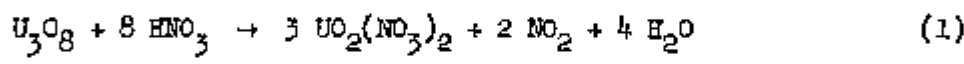

The uranium is purified by solvent extraction using tributyl phosphate in kerosene as the solvent. Extraction, scrubbing, and product stripping are accomplished in glass and stainless steel columns. Stainless steel mixer-settler equipment is employed to clean used solvent and to remove traces of solvent impurities from the product uranyl nitrate hexahydrate solution. Product concentration to about 10 pounds of uranium per gallon is carried out in vertical tube evaporators and holddown tanks heated by steam coils. Solvent extraction raffinates are neutralized and disposed of in seepage pits. Nitric oxide fumes from the denitration step are piped to the waste handling area and are neutralized with caustic in a scrub tower; however, for the 500 tons U/yr case, approximately 50% of the nitric acid may be recovered by contacting with water in a vertical tower.

For the 25, 50, and 100 tons/yr cases, the uranium trioxide is fluorinated directly to uranium hexafluoride with elemental fluorine using a flame reactor.



Unreacted material, relatively

DELETED

~~TRD~~ DOE  
6, 2(1)

high in beta radioactivity, is caught in an ash receiver bolted to the bottom of the reactor. When an ash receiver is filled, it is replaced and held for about three months to permit decay of the uranium daughter products of short half life. The ash is subsequently ground and refed to the fluorinator. A small amount of ash is also collected in the fluorinator off-gas filter system; this material contains the largest part of the non-volatile impurities and is accordingly reprocessed through the ore concentrate solvent extraction system.

The uranium hexafluoride is separated from the product gas stream by batch cold traps, and the uranium hexafluoride that is collected is drained as a liquid to cylinders.

All items of equipment and piping in contact with uranium hexafluoride are constructed of Monel. The oxide hopper and the rotary dispersers are made of steel.

For the 500 tons U/yr case, it is probably expedient to reduce the uranium trioxide to uranium dioxide with hydrogen and to convert the uranium dioxide to uranium tetrafluoride with hydrogen fluoride prior to treatment with fluorine. To accomplish the reduction and hydrofluorination, two-stage fluid bed reactors are used for each step with hydrofluorination reactors being of the stirred fluid bed variety.



Fluorination is carried out in a flame reactor, and ash handling is as described above for the other cases.

Except for the mild steel feed hoppers, reduction equipment -- piping, valving, etc -- is constructed of stainless steel. Hydrofluorination reaction equipment is made of Inconel; all hopper screws, filter tubes, piping, valves, etc are Monel.

Fluorine may be produced from 6,000-ampere Monel cells, and hydrogen fluoride is removed from the fluorine stream by cold traps followed by sodium fluoride. Hydrogen is generated from cracked ammonia. Hydrogen fluoride could be bought in 6,000-gallon tank car lots for the 500 tons U-yr case; 200-pound cylinders should suffice for the other three cases.

#### METALS PLANT

Two different size metals plants were estimated here, one to handle 50 kg of metal per year, the other 500 kg per year. The plant, capital, operating, and maintenance costs are presented in Tables 24 and 25. Briefly the process which probably would be used can be described as follows:

~~SECRET~~

43

~~SECRET~~

DOE  
62(a)

DELETED

Casting skulls will be burned to oxide, leached, extracted, and returned to wet chemistry for precipitation. Machining chips will be recycled to reduction. All massive metal will be returned to casting. The wet chemistry and reduction salvage will probably be discarded.

~~SECRET~~



TABLE 9

## ESTIMATED MANPOWER AND CAPITAL FOR CENTRIFUGE PLANT CONSTRUCTION AND OPERATION IN U.S.

Machine Identification: A, Original Zippe, 350 m/sec  
 Product Rate: 50 Kg U per year

<u>Capital Cost</u>	<u>Dollars</u>	<u>Dollars</u>	<u>Construction Manpower and Scheduling</u>	
Centrifuge		12,494,000	Peak Manpower:	<u>Men</u>
Electrical	6,831,000		Engineering	72
Casing	20,434,000		Non Manual	140
Instrumentation	7,861,000		Annual	860
Mechanical	9,464,000		Total Manpower:	<u>Man-Months</u>
Building	8,395,000		Engineering	1,700
Total Direct Construction Cost		52,985,000	Non Manual	2,310
Indirect Construction Cost		21,186,000	Manual	14,450
Test and Start-up		1,762,000		
Total Capital Cost		88,427,000	<u>Minimum Time Req'd, months:</u>	45
<u>Operating Manpower and Costs</u>		<u>Men</u>	<u>\$/Year</u>	<u>\$/Year</u>
Direct Operating Labor		335	2,297,000	
Direct Maintenance Labor		335	2,297,000	
Total Direct Labor			4,594,000	
Overhead at 100%			4,594,000	
Works Laboratory Technicians		6	40,000	
Technical Supervision		11	32,000	
Technical and Scientific Staff		10	120,000	
Total Labor		697		9,480,000
Materials			792,000	
Power			268,000	
Total Materials				1,060,000
Total Operating Cost				10,540,000
	<u>No. of Centrifuges</u>	<u>Feed Rate, tons/yr</u>	<u>Tails Concentration, % U-235</u>	
	19,800	70	0.0065	

~~SECRET~~

~~SECRET~~

DOE  
6.2(a)

TABLE 10  
ESTIMATED MAINTENANCE AND CAPEX, FOR CONSTRUCTION PLANT CONSTRUCTION, BY QUARTER, 1975-1985.

**DELETED**

~~SECRET~~

~~SECRET~~

~~SECRET~~

TABLE 1.1

ESTIMATED COSTS AND CAPITAL FOR CENTRIFUGE PLANT CONSTRUCTION AND OPERATION IN U.S.

**DELETED**

5.2  
DOE  
(6.2.12)

DOE  
6.2(a)

TABLE 12

ESTIMATED MAINTENANCE AND CAPITAL COSTS FOR PLANT CONSTRUCTION AND OPERATION IN 1975

**DELETED**

TABLE 13

ESTIMATED MAINTENANCE AND CAPITAL FOR CENTRIFUGAL PLANT CONSTRUCTION AND OPERATION, 1967.

DELETED

TABLE 14

ESTIMATED ENERGY AND CAPITAL FOR STEAM-GENERATOR PLANT CONSTRUCTION AND OPERATION IN U.S.

DELETED

45

DOE  
6/2/69

TABLE 45

ESTIMATED MAINTENANCE AND CAPITAL FOR CENTRIFUGAL PLANT CONSTRUCTION AND OPERATION 1964

**DELETED**

~~SECRET~~

52

~~SECRET~~

004  
6-26

~~SECRET~~

DOE  
G.2(a)

TABLE 16

ESTIMATED MAINT. & AMPL CAPITAL FOR CENTRIFUGE PLANT CONSTRUCTION AND OPERATION IN U.S.

**DELETED**

~~SECRET~~



6.2(a)

TABLE 17

ESTIMATED MAINTENANCE AND CAPITAL FOR CENTRIFUGE PLANT CONSTRUCTION AND OPERATION IN U.S.

DELETED

TABLE 18

ESTIMATED MAINTENANCE AND CAPITAL FOR CERQUELONNE PLANT CONSTRUCTION AND OPERATION IN U.S.

DELETED

DOE  
(Gale)

TABLE 19

ESTIMATED MANPOWER AND CAPITAL FOR CENTRIFUGE PLANT CONSTRUCTION AND OPERATION IN U.S.

**DELETED**

59

00E  
6.2(2)

TABLE 20

ESTIMATED MANPOWER AND CAPITAL FOR FEED PLANT CONSTRUCTION AND OPERATION IN U.S.  
Feed Rate: 25 M per year

<u>Capital Costs, Dollars</u>		<u>Construction Manpower and Scheduling</u>	
<u>Installed Equipment:</u>		<u>Peak Manpower:</u>	
Solvent Extraction	133,000		<u>Men</u>
Fluorinator and Cold Trap	73,000	Engineering	6
Fluorine System	106,000	Non Manual	2
Auxiliary Chemistry Systems	18,000	Manual	72
Spare Equipment	65,000		
Piping 210,000		<u>Total Manpower:</u>	
Instrumentation	58,000		<u>Man-Months</u>
Utilities	33,000	Engineering	60
Maintenance Facility	32,000	Non Manual	30
Administrative, Laboratory	36,000	Manual	590
Building	209,000		
Direct Construction Costs	973,000	<u>Time Required: 11 Months</u>	
Start-Up	99,000		
Engineering, Design and Inspection	126,000		
Indirect Construction Costs	189,000		
Contingency	194,000		
Total	1,581,000		

Operating Manpower and Costs, Dollars Per Year (5 days/week, 24 hours/day)

<u>Labor:</u>		<u>Materials:</u>	
9 Chemical Operators	59,000	Direct Materials	24,000
9 Maintenance	59,000	Maintenance Materials	40,000
1 Super.	9,000	Other Materials	15,000
1 Clerk	6,000	Total Materials	79,000
Overhead at 100%	133,000		
2 Laboratory Technicians (including overhead)	32,000	Total Operating Cost	395,000
1 Engineer (including overhead)	18,000		
Total Labor	316,000		

TABLE 21

ESTIMATED MANPOWER AND CAPITAL FOR PEBB PLANT CONSTRUCTION AND OPERATION IN U.S.  
Feed Rate: 50 TK per year

<u>Capital Costs, Dollars</u>		<u>Construction Manpower and Scheduling</u>	
Installed Equipment:		Peak Manpower:	
Solvent Extraction	145,000		<u>Men</u>
Fluorinator and Cold Trap	97,000	Engineering	8
Fluorine System	153,000	Non Manual	12
Auxiliary Chemistry Systems	26,000	Manual	90
Spare Equipment	82,000		
Piping	261,000	Total Manpower:	
Instrumentation	74,000		<u>Man-Months</u>
Utilities	44,000	Engineering	80
Maintenance Facility	42,000	Non Manual	120
Administrative, Laboratory Building	254,000	Manual	560
Direct Construction Costs	1,222,000	Time Required:	11 Months
Start-Up	155,000		
Engineering, Design and Inspection	154,000		
Indirect Construction Costs	240,000		
Contingency	238,000		
Total	1,989,000		

Operating Manpower and Costs, Dollars Per Year (5 days/week, 24 hours/day)

<u>Labor:</u>		<u>Materials:</u>	
12 Chemical Operators	79,000	Direct Materials	44,000
11 Maintenance	75,000	Maintenance Materials	51,000
1 Supervisor	9,000	Other Materials	20,000
1.5 Clerks	8,000	Total Materials	115,000
Overhead at 100%	171,000	Total Operating Cost	532,000
3 Laboratory Technicians (including overhead)	48,000		
1.5 Engineers (including overhead)	27,000		
Total Labor	417,000		

TABLE 22

ESTIMATED MANPOWER AND CAPITAL FOR FEED PLANT CONSTRUCTION AND OPERATION IN U.S.  
Feed Rate: 100 TJ per year

<u>Capital Costs, Dollars</u>		<u>Construction Manpower and Scheduling</u>	
<u>Installed Equipment:</u>		<u>Peak Manpower:</u>	
			<u>Men</u>
Solvent Extraction	188,000	Engineering	10
Fluorinator and Cold Trap	129,000	Non Manual	15
Fluorine System	202,000	Manual	116
Auxiliary Chemistry Systems	33,000		
Spare Equipment	108,000		
		<u>Total Manpower:</u>	
Piping	344,000		<u>Man-Months</u>
Instrumentation	98,000	Engineering	100
Utilities	58,000	Non Manual	140
Maintenance Facility	52,000	Manual	1,110
Administrative, Laboratory	57,000		
Building	308,000		
		<u>Time Required:</u>	<u>11 Months</u>
Direct Construction Costs	1,577,000		
Start-Up	173,000		
Engineering, Design and Inspection	210,000		
Indirect Construction Costs	316,000		
Contingency	515,000		
<b>Total</b>	<b>2,591,000</b>		

Operating Manpower and Costs, Dollars Per Year (5 days/week, 24 hours/day)

<u>Labor:</u>		<u>Materials:</u>	
14 Chemical Operators	92,000	Direct Materials	53,000
5 Maintenance	98,000	Maintenance Materials	5,000
1, Supervisors	14,000	Other Materials	2,000
2 Clerks	21,000	<b>Total Materials</b>	<b>173,000</b>
Overhead at 100%	216,000		
3.5 Laboratory Technicians (including overhead)	54,000	<b>Total Operating Cost</b>	<b>694,000</b>
2 Engineers (including overhead)	36,000		
<b>Total Labor</b>	<b>521,000</b>		

TABLE 23

ESTIMATED MANPOWER AND CAPITAL FOR FEED PLANT CONSTRUCTION AND OPERATION IN U.S.  
Feed Rate: 500 TQ per year

<u>Capital Costs, Dollars</u>		<u>Construction Manpower and Scheduling</u>	
<u>Installed Equipment:</u>		<u>Peak Manpower:</u>	
Solvent Extraction	295,000		<u>Men</u>
Fluorination and Cold Trap	213,000		
Fluorine System	284,000	Engineering	19
Auxiliary Chemistry Systems	106,000	Non Manual	29
Spare Equipment	201,000	Manual	215
Piping	628,000	<u>Total Manpower:</u>	
Instrumentation	199,000		
Utilities	115,000		<u>Man-Months</u>
Maintenance Facility	68,000	Engineering	180
Administrative, Laboratory	70,000	Non Manual	280
Building	426,000	Manual	2,060
Direct Construction Costs	2,605,000	<u>Time Required: 11 Months</u>	
Start-Up	290,000		
Engineering, Design and Inspection	407,000		
Indirect Construction Costs	392,000		
Contingency	578,000		
<b>Total</b>	<b>4,472,000</b>		

Operating Manpower and Costs, Dollars Per Year (5 days/week, 24 hours/day)

<u>Labor:</u>		<u>Materials:</u>	
17 Chemical Operators	112,000	Direct Materials	254,000
28 Maintenance	153,000	Maintenance Materials	124,000
2 Supervisors	18,000	Other Materials	28,000
2 Clerks	11,000	Total Materials	405,000
Overhead at 100%	324,000		
4 Laboratory Technicians (including overhead)	64,000	Total Operating Cost	1,163,000
2.5 Engineers (including overhead)	45,000		
<b>Total Labor</b>	<b>757,000</b>		

TABLE 24  
 ESTIMATED MANPOWER AND CAPITAL FOR METAL COMPONENT FACILITY  
 CONSTRUCTION AND OPERATION IN U. S.  
 Product Rate: 50 Kg U per year

<u>Capital Costs, Dollars</u>		<u>Construction Manpower and Scheduling</u>	
<u>Installed Equipment:</u>		<u>Peak Manpower:</u>	
Wet Chemistry Process	24,000		<u>Men</u>
Reduction Bombs	8,000		
Casting Equipment	44,000	Engineering	2
Machining and Testing Facility	50,000	Non Manual	2
Recycle Equipment	20,000	Manual	5
Piping	14,000	<u>Total Manpower:</u>	
Instrumentation	5,000		
Utilities	32,000		<u>Man-Months</u>
Building	24,000	Engineering	20
Direct Construction Costs	221,000	Non Manual	20
Engineering, Design and Inspection	25,000	Manual	50
Indirect Construction	64,000	<u>Time Required: 9 Months</u>	
<b>Total</b>	<b>310,000</b>		

Operating Manpower and Costs, Dollars Per Year (40-Hour Week Operation)

<u>Labor:</u>	
2 Operators	30,000
1 Maintenance	
1 Engineer	30,000
1 Supervisor	
Overhead	60,000
Materials	28,000
<b>Total</b>	<b>148,000</b>



TABLE 25

ESTIMATED MANPOWER AND CAPITAL FOR METAL COMPONENT FACILITY  
 CONSTRUCTION AND OPERATION IN U. S.  
 Product Rate: 500 Kg U per year

<u>Capital Costs, Dollars</u>		<u>Construction Manpower and Scheduling</u>	
<b>Installed Equipment:</b>		<b>Peak Manpower:</b>	
Wet Chemistry Process	49,000		<u>Men</u>
Reduction Booms	16,000		
Casting Equipment	44,000	Engineering	2
Machining and Testing Facility	70,000	Non Manual	3
Recycle Equipment	30,000	Manual	7
Piping	19,000		
Instrumentation	6,000	<b>Total Manpower:</b>	
Utilities	42,000		<u>Man-Months</u>
Building	50,000	Engineering	20
Direct Construction Costs	326,000	Non Manual	30
		Manual	70
Engineering, Design and Inspection	30,000	<b>Time Required:</b>	11 Months
Indirect Construction	83,000		
<b>Total</b>	<b>439,000</b>		

Operating Manpower and Costs, Dollars Per Year (40-Hour Week Operation)

Labor:

6 Operators	
3 Maintenance	90,000
2 Engineers	
1 Supervisor	57,000
1 Chemist	
Overhead	147,000
Materials	250,000
<b>Total</b>	<b>544,000</b>

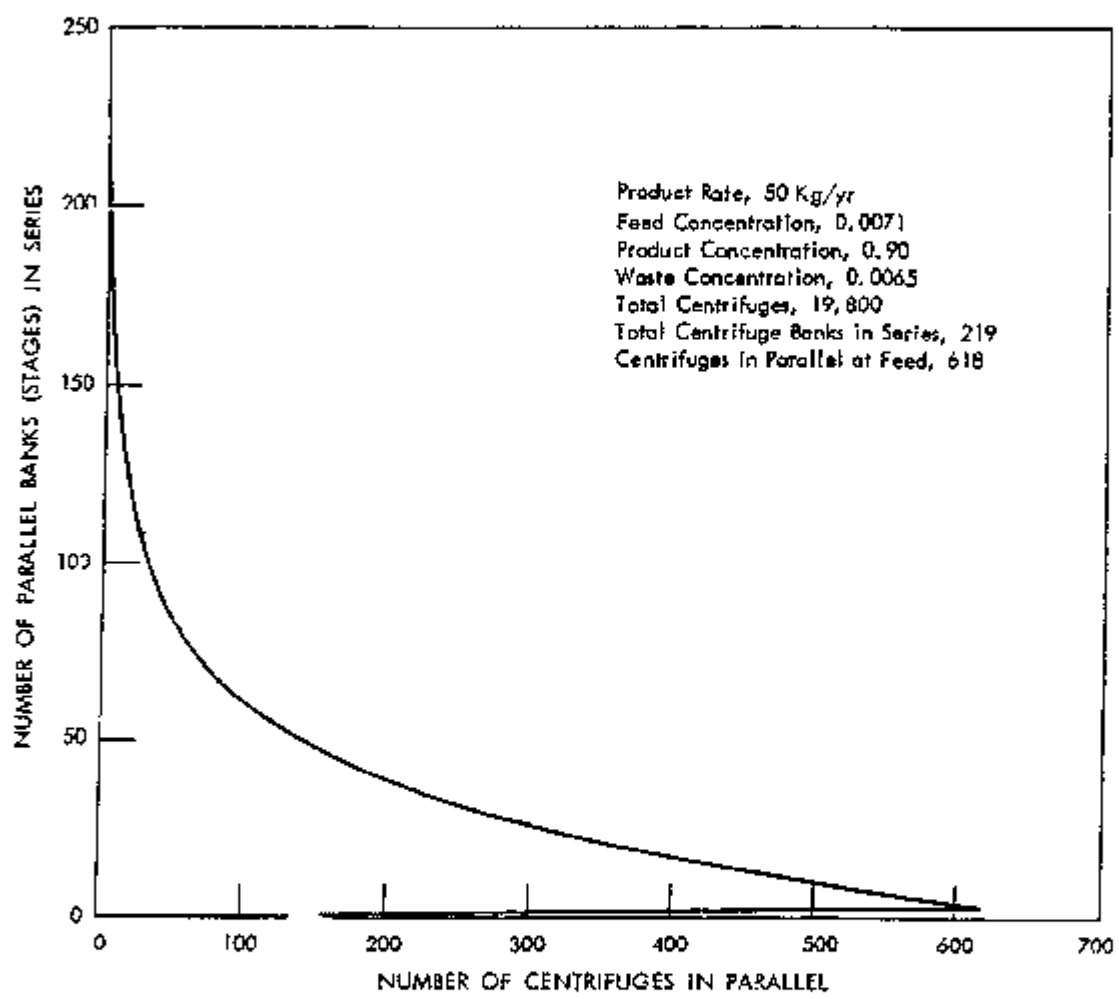
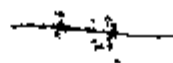

Figure 9  
LAYOUT OF IDEAL PLANTS CONTAINING  
SUBCRITICAL CENTRIFUGES, MODEL A,  
3 in., 350 m/sec

DOE  
6.2(9)

~~SECRET~~

67

**DELETED**

~~SECRET~~

~~SECRET~~

cc

**DELETED**

~~SECRET~~

DOE  
6.2(G)

~~SECRET~~ →

03

**DELETED**

~~SECRET~~

~~SECRET~~

DOE  
6.2(a)

TO

**DELETED**

~~SECRET~~

DOE  
6.2(a)

~~SECRET~~

71

**DELETED**

~~SECRET~~

## DISCUSSION

## FEASIBILITY OF CLANDESTINE OPERATION

Any nation in groups X, Y, and Z could, if sufficiently motivated, build a gas centrifuge plant which would produce sufficient fissionable material for the construction of a nuclear weapon. The gas centrifuge plant lends itself to clandestine operation. The power requirements for the centrifuge plants under consideration will be relatively small; and since it is possible to obtain a relatively large separation in a single centrifuge, the number of centrifuges required for the plant, particularly if they are of an advanced design, is considerably less than the number of gas diffusion stages which would be required for this same production goal. Therefore, a small centrifuge plant can be contained in a building of modest dimensions; such a plant would be difficult to detect, especially in an industrial country.

A class X country could build a clandestine centrifuge cascade for production of even the 500-kg U per year quantity with very little outside assistance and with little drain on its economy. A class X country will have several large universities, and in general, all will have conducted research of varying description pertaining to problems in isotope separation. Any type X country will have the experienced scientists and engineers necessary to bring a centrifuge plant into successful operation. Similarly, a class X country will have no problem in obtaining the services of skilled machinists for constructing the centrifuges, nor in recruiting trained operators and maintenance men for running the plant. The special materials required for construction of the isotope separation plant and the related facilities would most likely be readily available in a class X country, or if not, could be purchased without arousing any suspicion, due to the high level of domestic industrial activity. Many of the special items such as spectrometers, special instrumentation, etc could be purchased by a class X country through a university, for its research department, without inviting attention. Furthermore, the countries in this category already have, or may be expected in the very near future to have, nuclear power programs. Thus, these countries will have a valid requirement for research reactors and uranium ore. It would not be possible without safeguards (fuel or adequate controls to detect the relatively small diversions of uranium necessary to provide feed to a small isotope separation cascade under these circumstances.

A class Y country may be characterized as a country which possesses technological competence, but which has limited industrial activity. A class Y country could not build a centrifuge plant without some outside assistance; however, it could probably adequately disguise the nature of its activities from the outside world at least for the low production rate facility. A class Y country may be assumed to have a sufficient number of scientists and engineers to bring a centrifuge facility to successful completion. Since these men may lack specific experience of this nature, it may be assumed that it would take appreciably longer for a class Y country to achieve successful operation than it would a class X country. A class Y country would have some difficulty in recruiting the skilled



machinists, operators, and maintenance men necessary to construct and operate the isotope separation plant. A class Y country would in all likelihood have to import much of the hardware necessary to fabricate the centrifuges and also some of the auxiliary equipment required for the plant. The material of construction for the centrifuge bowl would probably have to be imported; however, since further machining and assembly could be done after delivery, the use to which this material is to be put may not be evident. A class Y country would also have to import other materials such as motor generator sets for high frequency currents, process control equipment, mass spectrometers, and other items of a specialized nature. These orders could, however, be distributed among a large number of vendors, in order to prevent detection of the construction effort for the small production rate plants; it would however be much more difficult to prevent detection with the larger plants. Class Y countries may well have access to uranium ore either by virtue of their domestic nuclear power program or their own natural resources. If not, they would have to procure it elsewhere and this may provide a method of detection. There are, however, many countries able to export uranium ore, and one should remember that the 25 tons per year or so required for the small production rate plant is a relatively small quantity of ore. The high production rates requiring hundreds of tons per year of ore would probably present a problem of detection in a class Y country not having its own ore supply.

A class Z country would find the construction and operation of a centrifuge facility a difficult task. The total capital investment which amounts to about \$43.5 million for the model C centrifuge facility (for the low production rate), coupled with the operating costs of about \$4.5 million per year would be in the case of a class Z country quite a burden on the economy. A class Z country would have to be highly motivated to undertake such an expensive project. However, the lower construction and operating costs estimated with the more advanced centrifuge models would certainly make the project more feasible for a class Z country. A class Z country would need a great deal of outside assistance both in manpower and in material in order to bring a centrifuge plant into successful completion. Countries in this category would probably need technical advisers from abroad, competent scientists and engineers to aid in development of an operable facility. Operators and maintenance men would have to be trained for their particular jobs. A class Z country would probably not have sufficient skilled machinists to fabricate the centrifuges. It would be expected, therefore, that a type Z country would purchase fabricated centrifuges. Their alternative would be to train the necessary machinists and to purchase the lathes, drill presses, and other shop equipment which would be required for the manufacture of centrifuges. In addition to the centrifuges, almost all of the auxiliary equipment required for a centrifuge plant would have to be purchased from foreign vendors.)

**DELETED**

Furthermore, the plant itself would probably be more difficult to hide in a nonindustrial country. In short, it appears that a class Z

DOE  
1.4(C)  
6.2(a)

country could not build a completely clandestine nuclear weapons facility. It could, however, with the collaboration of a class X or Y country build such a facility, but even then it would have much more difficulty hiding it than would a class X or Y country.

MINIMUM TIME REQUIRED TO PRODUCE THE FIRST NUCLEAR WEAPON

The minimum times estimated for the production of the first nuclear weapon with the centrifuge process in countries X, Y, and Z are presented in Table 8 for both the present centrifuge, model C, and the very advanced models K and L.

**DELETED**

DJF  
(624)  
140

These times can be compared with 3.5 years for the United States. The minimum time estimated for the development of the highly advanced centrifuges, models K and L, is five years.

**DELETED**

DJF  
146

If the results of the centrifuge development efforts were not available from the United States or from some other highly advanced country and the countries have to develop the centrifuge on their own, it is estimated that a class X country without an already well-developed centrifuge program would require an additional 2 to 3 years over the times presented for the present centrifuge, model C. A class Y country would require an additional 4 to 5 years for model C and would probably not attempt to develop a more advanced centrifuge, and a class Z country could probably never develop the centrifuge on its own.

OPERATING AND MAINTENANCE

At this particular time in the centrifuge development, estimating the required maintenance and the number of operators needed for the safe and efficient operation of a gas centrifuge plant is extremely difficult. It is felt that the costs presented here reflect optimistic thinking, and the future costs and estimates are not expected to be lower. The actual staffs required for the operation of the centrifuge plants in the early stages, until the problems and uncertainties are resolved, could be larger than those presented here.

CAPITAL AND OPERATING COST ESTIMATES

**DELETED**

DJF  
140  
620

**DELETED**

With the more advanced centrifuge, these operating costs may be reduced to \$935,000, \$1,052,000, and \$1,065,000 for the class X, Y, and Z countries, compared with \$9-7,000 for the United States.

**KEY AREAS INDICATING POTENTIAL FOR WEAPONS PRODUCTION**

A class X country, due to its large industrial capacity, could probably construct and place in operation a centrifuge facility without any outside assistance, and without arousing undue suspicion. Both a class Y and Z country would require outside assistance and the purchase of many items outside their own country. The key items, whose manufacture or purchase in quantity would serve as an alarm that a centrifuge plant may be in operation or under construction, are listed in Table 26. Any one of these items may mean nothing, but a combination of them should indicate the possibility of a centrifuge facility.

TABLE 26

**DELETED**

67  
142  
141

**CORRELATION OF INDUSTRIAL CAPABILITY OF NATIONS**

To estimate the order in which the various nations can be expected to achieve an isotope separation process and the time required for this accomplishment, it is necessary to choose some feature or features of a nation's economy which are indicative of that nation's industrial competence.

The two such features which reflect all areas of modern industrial

activity are the consumption of electrical energy and the consumption of steel. Furthermore, the per capita value of these quantities provides a measure of the level or relative effectiveness of application of a nation's industry, since per capita consumption is itself an empirical statement of demonstrated effectiveness.

Accordingly, the following quantities were defined:

$$\text{Relative Industrial Size, S} = \sqrt{\frac{\text{Steel Consumption}}{\text{US Steel Consumption}} \cdot \frac{\text{Electrical Energy Consumption}}{\text{US Electric Energy Consumption}}}$$

$$\text{Relative Industrial Level, L} = \sqrt{\frac{\text{Per Capita Steel Consumption}}{\text{US Per Capita Steel Consumption}} \cdot \frac{\text{Per Capita Electric Energy Consumption}}{\text{US Per Capita Electric Energy Consumption}}}$$

$$\text{Relative Industrial Capability} = \sqrt{S \cdot L}$$

The Relative Industrial Capability (RIC) was then related to actual time, cost, and manpower requirements by correlating the industrial experience of nations for which such data were available with the computed RIC's of those nations.

The results of the correlations are shown in Figure 15 in which factors for converting United States requirements into the requirements of other nations are shown for man-months required for building a plant, the time which will elapse between inception and end of construction, the number of men engaged in construction or operation of the plant (applicable to peak work force in the case of construction), the construction or capital cost, and the annual operating cost. In each case an estimate made for the United States may be multiplied by the appropriate factor of Figure 15 to obtain the corresponding estimate for a nation for which the RIC has been computed.

The RIC was computed for a variety of nations, and these are located on Figure 15. Also shown are the zones which define the X, Y, and Z categories of nations referred to in this report.

Statistical data used in computing the RIC were obtained from "Statistical Abstract of the United States" which contains international statistical data drawn chiefly from the United Nations Statistical Office. This Agency's annual publication, "Statistical Yearbook," provides a wide variety of detailed statistical data.

SECRET

Figure 15  
RELATIVE INDUSTRIAL CAPABILITIES

DEC 2  
1943

CLAUDESTINE PRODUCTION OF ENRICHED URANIUM  
BY THE SWEEP DIFFUSION PROCESS

Although the previous sections of this report have dealt exclusively with the possible production of enriched uranium by the centrifuge process, there are other processes which might be better matched with the lower technological capabilities of Y and Z foreign powers. Such a process, for example, would be sweep diffusion. In the sweep diffusion process, a gaseous mixture of isotopes is confined in a separation unit through which flows a current of a third component called the sweep gas or sweep vapor. As the sweep vapor flows through the process gas mixture, it tends to sweep along the heavy, or less diffusible, component. In common applications of this process, the sweep vapor is chosen so that it can be easily condensed on a cold vertical wall. The falling film of condensed sweep vapor then drags the process gas downward with it, setting up an axial circulation or countercurrent flow, as shown in Figure 16, which multiplies the simple process separation factor. It is envisioned that a sweep diffusion column could be built in the form of two concentric tubes, the inner one being porous and serving to distribute the sweep vapor which is introduced into the central region. The separation region would then be in the annulus, and the entire column would be immersed in a coolant bath so that the outer tube would act as a condenser for the sweep vapor. Such columns would be relatively easy to construct, and a number of the columns could be put in a common coolant jacket to reduce costs and make the plant more compact.

DELETED

The costs estimated for the sweep diffusion process must be regarded as of a most preliminary nature since the process has not been proved experimentally. The costs are based on an efficiency factor of 50% for the sweep diffusion plant based on the maximum separative capacity of the columns. The power requirement for sweep diffusion will be the order of that for gaseous diffusion and will thus be much greater than for a centrifuge plant of similar size.

The solubility of the process gas in the condensed sweep vapor is one of the problems which must be overcome if the sweep diffusion process is to reach its theoretical potential. If the process gas is appreciably soluble, and this mixture is then vaporized and reintroduced into the columns, a serious loss in separative work would be incurred because the process gas in the sweep vapor stream is at the average plant concentration in the desired isotope and it is being remixed with process gas at the point concentration in the concentration gradient. A study of this remixing effect shows that separative work losses greater than 50% are probable with sweep vapors of the Freon family.

If the solubility problem could be solved by proper choice of the sweep vapor, or if the effect could be mitigated by careful process design, the sweep diffusion process might be a very attractive means of enriching

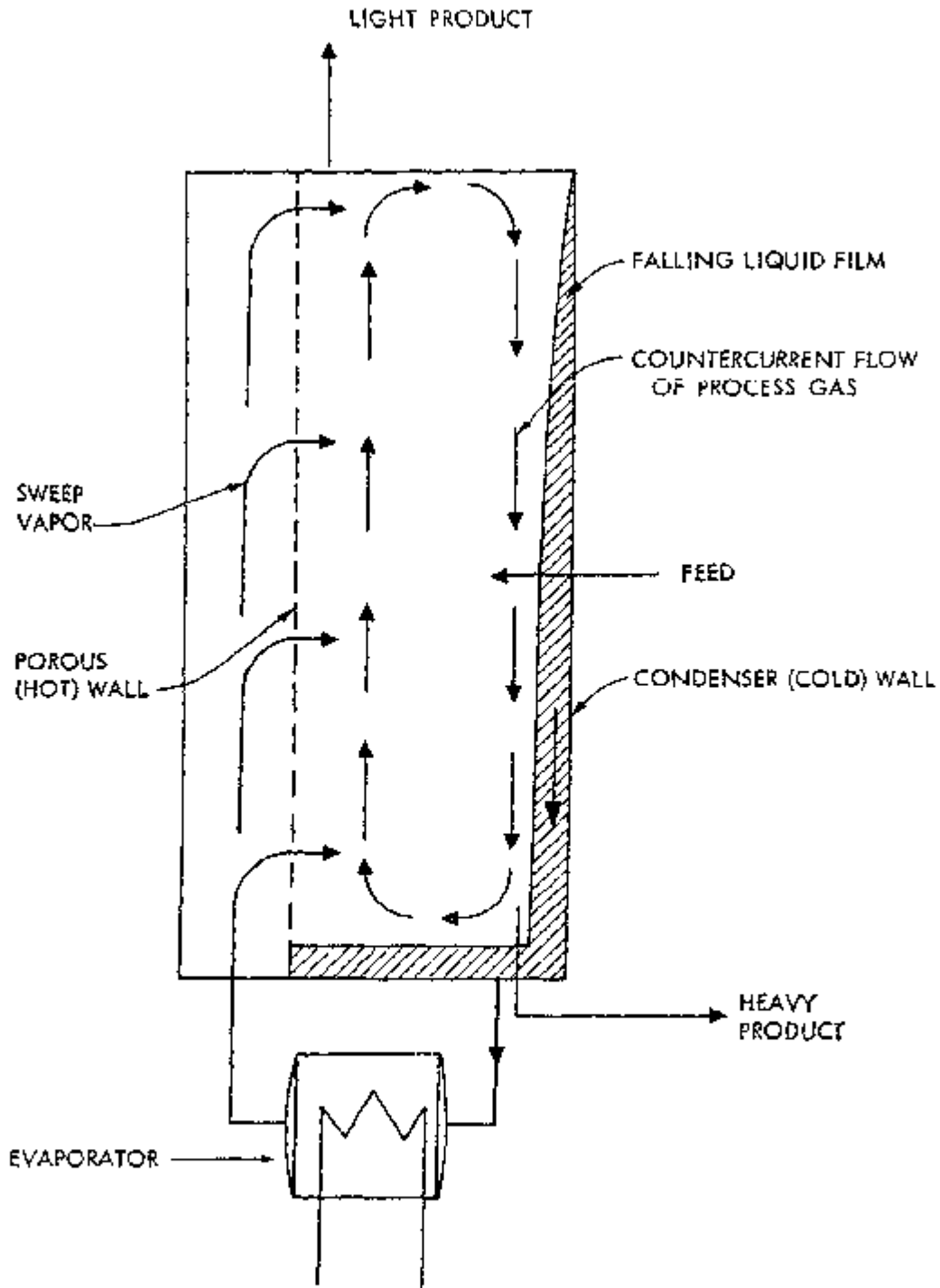

Figure 16  
SCHEMATIC REPRESENTATION OF A  
SWEEP DIFFUSION COLUMN

uranium in a country that lacks the technological sophistication to build gas centrifuges. A sweep diffusion plant requires process equipment such as nickel plated pipe and screen, rotary lobe blowers to move the process gas from cascade to cascade, centrifugal pumps to pump the condensed sweep vapor to the evaporators, and the evaporators themselves.

A preliminary investigation of the sweep diffusion process for the separation of other isotopes is being considered, which would also determine its potential for uranium isotope separation. One of the more serious problems which would have to be overcome is the solubility of process gas in the condensed sweep vapor.

## REVIEW AND EVALUATION OF FOREIGN CENTRIFUGE PROGRAMS

### INTRODUCTION

The current status of gas centrifuge development programs in foreign non-Communist countries is reviewed in this section of the report, and an evaluation of the program in each country is made with respect to its scope, direction, ultimate goals, and chances for success. The experience acquired in carrying out the centrifuge development program in the United States has been utilized in the preparation of these evaluations. The information on the current status of the centrifuge project in each country has been compiled from the following sources:

The open scientific literature

The press

Interview and trip reports prepared by AEC personnel which are available in the classified scientific literature

Classified intelligence documents.

This work supersedes a previous report<sup>(2)</sup>. From the information available, it appears that only four foreign countries outside the Communist Bloc are making any serious effort to develop a gas centrifuge process for the enrichment of the uranium isotopes. These are:

England

Japan

The Netherlands

West Germany

In addition, Brazil has maintained an interest in its rather modest centrifuge program, and France has recently been reported engaged in centrifuge development.

In general, little new information has become available since the preparation of the earlier report. This is due in large part to the fact that European nations agreed at the end of 1960 to accede to the request of the United States that security restrictions be imposed regarding developments in the centrifuge process. Exceptions to this are England, with which the United States has an information exchange program, and Japan where probably for political reasons the work is entirely unclassified.



Nevertheless, it is not possible that because of the furor which centrifuge developments evoked in the press in 1960 that almost every third X country has undertaken a centrifuge program of some sort, even if quite small. The Communist Bloc countries have been excluded from this evaluation for the simple reason that practically no information is available. It seems reasonable to presume that the centrifuge program which Russia pursued in the years following World War II from 1949 to 1954 was abandoned when the German scientists working on the project were repatriated. Dr. Zippe, one of the scientists who worked on the Russian project, has recently reported that the Russians have resumed work on centrifuge development. It is reasonable to suspect that this report is correct; however, no specific information has been made available to the West. Similarly it is reasonable to believe that the East German scientists, some of whom also worked on the Russian project, are presently pursuing their investigations for the East German Government. But again, no details are available.

As complete a description as is possible and an evaluation of the program in each of the various countries is given in the following sections.

#### BRASIL

Description of the Centrifuge Program. It is well known that Brazil has three centrifuges built in West Germany which are located at the Institute of Technological Research at the University of Sao Paulo in Sao Paulo, Brazil. According to information received, Dr. Massei is the director of the Institute, and Professor Ivo Jordan is in charge of the centrifuge project. A statement by Jordan verified that the three centrifuges owned by the Institute were imported from Germany in 1958 and placed in operation in March, 1959.

DOE  
1.4(6)  
1.4(0)

**DELETED**

The only published article containing experimental separation data obtained with the Brazilian machines deals with the separation of the isotopes of argon (3). According to this paper written by Groth et al. in 1960, the

Brazilian centrifuge are of the type which Groth has designated as 'e' ZG5. The ZG5 has a rotor length of 56.5 centimeters and a diameter of 15.3 centimeters, and is designed for a peripheral speed of 302 m/sec. Further information on the ZG5 is given in the section on the West German centrifuge program.

Admiral Cunha, president of Brazil's nuclear energy commission, has stated that Brazil has no intention of producing a nuclear weapon, is interested only in peaceful applications of nuclear energy, and that Brazil's centrifuges are intended only for research and training purposes.

Evaluation of Program. The current Brazilian centrifuge program is relatively small involving, as far as is known, only the operation of the three machines which they purchased from West Germany.

**DELETED**

#### ENGLAND

Description of Program. The current status of the British centrifuge program is presumably well known to the USAEC by virtue of an agreement between the two governments effective in 1960 to exchange information on gas centrifuge technology. Members of the United States and the United Kingdom centrifuge teams met in accordance with this agreement in 1960, 1961, 1962, and 1963. It is anticipated that the next meeting between the two groups will take place in March, 1964. The information obtained during these meetings regarding the nature of the British program is contained in the US classified reports of the meetings (4, 5, 6, 7, and 8) and is summarized below.

00C  
1.4b1

DELETED

The United Kingdom development program has been in progress for about three years, having been initiated in October, 1960. The first two-year program for which 300,000 pounds sterling (or about \$840,000) was budgeted was aimed at developing "a respectable machine with a good efficiency and an extraction system which can be used by engineers to make a cascade." In October, 1962, a second two-year program was authorized at a budget level of 350,000 pounds sterling (or about \$980,000). The stated goal of the present program is the successful operation of a cascade of centrifuges.

00C  
1.4b)  
6c1a)

DELETED

DOE  
6.2(a)  
1.4(b)  
1.4(c)

**DELETED**

The future plans of the current UK centrifuge program include:

Operation of an improved relatively low speed subcritical machine,

The operation of a high speed subcritical machine,

The operation of a relatively low speed supercritical machine, and

Operation of a cascade.

**DELETED**

DOE  
6.2(a)  
1.4(b)

DOE  
1.4(b)  
1.4(c)

Evaluation of Program.

**DELETED**

205  
1.7.61  
140

**DELETED**

**JAPAN**

Description of the Program. Japan has been conducting research on the enrichment of the isotopes of uranium by means of the gas centrifuge process on a relatively small scale at the Institute of Physical and Chemical Research in Tokyo. The program was initiated in FY 1958. All of the basic gas centrifuge work at the Institute on uranium enrichment has been directed by Dr. Yoshitoshi Oyama of the Tokyo Institute of Technology. The current staff working on the project at the Institute includes about 10 scientists and engineers plus three technicians. The Japanese program is financed by the Science and Technics Agency of the Japan Atomic Energy Bureau. A number of research contracts wholly financed by the Government have been entered into with various research and manufacturing groups including the Institute of Physical and Chemical Research, the Osaka Metal Industry Company, Ltd., Nippon Atomic Industry Group, and the Chemical Engineering Association.

The first Japanese experimental centrifuge was completed during FY 1959 at a reported cost of \$36,000.

DOG  
1.7.61

**DELETED**

The unit was manufactured by the Ishikawajima Harima Manufacturing Company, now a subsidiary of the Toshiba Company. The machine was patterned after the centrifuges designed by Groth in West Germany. Countercurrent flow is presumably obtained by means of a temperature difference between the two end caps. Most of the test efforts on this machine were directed toward working out the bugs in the system and dealt with balancing motor performance, effectiveness and durability of the seals, and determination of operating temperatures of the various components. Separation tests were attempted with neon, argon, and UF<sub>6</sub>. However, the neon separation tests failed because lubricating oil leaked into the rotor, and the UF<sub>6</sub> separation experiment failed due to the reaction of UF<sub>6</sub> with the oil; only the argon separation tests were at all successful.

DOG  
1.7.61

**DELETED**

~~SECRET~~

87

DOE  
1. 4(6)

**DELETED**

Although most of the uranium enrichment research work has been under the direction of the Institute of Physical and Chemical Research, beginning in FY 1963 the Japan Atomic Fuel Corporation was to take over this function including the experimental work at its Tokai-Mura Laboratories. Laboratory facilities are now being constructed to accommodate the work, and the two gas

~~SECRET~~

centrifuges will be transferred from the Institute to the Tokai Laboratories. Financing will continue through the Science and Technology Agency. No further tests are planned at the Institute on the unit which is now being dismantled for installation in the Japan Atomic Fuel Corporation Laboratory at Tokai-Mura where resumption of testing was scheduled for September, 1965. The ultimate objective of the AFC work is to develop a practical ultracentrifuge for use in a pilot-plant operation. All of the supporting research work on materials, bearings, seals, etc is aimed at achieving this objective. The technical problems and costs encountered to date are of greater magnitude than what was at first anticipated.

DOE  
1.4(6)

**DELETED**

Use of  $UF_6$  on an experimental basis is scheduled to start in FY 1964. AFC is now making plans to purchase  $UF_6$  production equipment including a mass spectrometer.

The work being done by the Nippon Atomic Industry Group (NAIG) of which the Toshiba Manufacturing Company is a predominant member includes basic research work on the development and testing of key items such as the rotors, bearings, seals, etc aimed at the eventual design and construction of a practical gas centrifuge (unit 3) capable of operating on  $UF_6$ . In this work NAIG is experimenting with different high-strength light weight  $UF_6$  and HF corrosion resistant materials such as various grades of duraluminum and fiberglass. The group hopes to be able to develop a practical gas centrifuge by 1966, capable of operation in a small pilot plant. The new unit would incorporate any improvements resulting from the testing of the two existing machines at AFC with the best engineering design developed at NAIG. NAIG is confident that a machine can be developed within this period which can be used to separate the isotopes of uranium economically.

NAIG is currently engaged in dismantling and transferring units 1 and 2 to Tokai-Mura. They will supply three technicians to help operate the units. The work at NAIG is under the direction of Mr. Kunio Yoshimura who has helped with the design of the two units at the Institute. He has traveled extensively in Europe in connection with the study of the gas centrifuge and appears to be well acquainted with the program under way both in Europe and in the United States.

The Ocesa Metal Industries Company, the leading fluorine producer in Japan, has performed research work since FY 1958 aimed at the production of  $UF_6$ . Development work on  $UF_6$ -handling apparatus is also in progress. An over-all study of plant design for uranium isotope separation was made by the Society of Chemical Engineers under direct contract with the Japan Atomic Energy Bureau. These studies include a feasibility analysis of the gaseous diffusion, gas centrifuge, and separation nozzle methods to determine the most practical route for Japan to follow, and to outline the technical problems involved with each of these methods.

DOE  
1.4(6)

**DELETED**



**DELETED**

In addition to the experimental work described above, two papers of a theoretical nature by Kangawa and Oyama appeared in the Journal of the Atomic Energy Society of Japan in late 1961. The first of these dealt with the effect of the flow pattern on the separative capacity of a centrifuge, and the second with the expected variation of the over-all separation factor and separative capacity of the centrifuge with the feed rate to the centrifuge. These papers are comparable with those written by the US investigators at the start of the USAEC centrifuge program and indicate a familiarity with the isotope separation theory developed by Karl Cohen and a basic understanding of the isotope separation processes in the gas centrifuge. However, in none of the published Japanese work do they make any comparison between the theory and their experimental results.

Evaluation of the Program. Despite the auspicious start made by the Japanese centrifuge program as measured by the progress achieved during the first year, the program seems to have foundered. Their second machine, which was to be essentially the equivalent of Groth's ZG5, fell appreciably short of this goal from a mechanical point of view, and furthermore on the basis of its separative capacity is much inferior to their original machine. This lack of success can be attributed in part to the fact that there appears to be no great urgency imposed upon the current program to develop a gas centrifuge of high separative efficiency. This attitude is probably influenced not only by the high cost and unexpected technical difficulties involved in developing the machine, but also because it is generally felt in Japan that a supply of enriched fuel for its second nuclear power plant (250-300 mw electrical) and probably for other future power reactors will be available from the United States or the United Kingdom or from other sources. Nevertheless, because it may become desirable sooner or later for Japan to produce her own enriched uranium supply, Japan has undertaken a centrifuge

development program aimed at constructing a practical centrifuge by FY 1960 which is to be followed by a small centrifuge pilot plant.

DOE  
1.4(b)  
1.4(c)

**DELETED**

~~SECRET~~

100  
100  
100

DELETED

THE NETHERLANDS

Historical Background. A review of the information available on the Dutch centrifuge development program makes quite apparent the fact that the Dutch have divulged very little information regarding the scope of their work nor have they given any indication of the progress which they may have made.

According to Kolstad<sup>(9)</sup> the Dutch centrifuge project is about six years old and in 1958, employed about 30 people. In spite of this there have been only two general papers plus a few patent applications from the Netherlands dealing with centrifuges and none of these is at all impressive. The two papers<sup>(10)(11)</sup> originated at the Laboratory for Mass Spectrography, F.O.M., Amsterdam, where Dr. J. Kistemaker heads the group working on the centrifuge project. In 1958 it was reported that this group had no centrifuges in operation, but were actively studying the component parts. It was reported by Kolstad, however, that the Germans believe that the best Dutch centrifuge work is being done at the Werkspoor N. V. Company. Little is known about the work there. One of the Dutch patents<sup>(12)</sup>, dated February 1958, describes a fiberglass centrifuge bowl. According to this patent, fiberglass is preferable to metal because of the ease of fabricating centrifuges from this material. Since no mention is made of ways to combat the problems of corrosion and of low tensile strength of the rotors in the axial direction, it is quite probable that no fiberglass materials had even been tested at that time.

There had been some co-operation between the Dutch and West Germans up through 1960 regarding centrifuge development. In a joint report to a meeting of the Executive Committee of the Research Syndicate for the Construction of a European Uranium Isotope Separation Plant, the Dutch and West German groups proposed the construction of a plant containing 40,000 to 60,000 centrifuges, which would produce annually 200 tons of uranium containing 1.4% U-235 and 7.7 tons annually of uranium containing 20% U-235 from 1000 tons of natural uranium ore and would require from 30 to 42 megawatts of power. No mention was made of the type of centrifuges to be used in the proposed plant.

The Dutch claim that the centrifuge which they are developing is different from the West German machine and requires less power for operation. In the paper which Kistemaker presented at Geneva in 1958<sup>(10)</sup> he mentioned four centrifuge models which may be indicative of the immediate goals of the Dutch program. The models are listed below.

~~SECRET~~

100

Model	Length, cm	Dia, cm	Peripher. Vel. St. m, m/sec	Separative Capacity, kg U/yr	Maximum Allowable Centrifuge Cost, \$/centrifuge
A	60	10	300	1.5	85
B	60	10	350	2.4	200
C	810	7	350	8.3	750
D	120	5.1	400	8.3	750

Each of the separative capacities in the above table is 15% of the maximum theoretical separative capacity of the machine. The maximum allowable centrifuge cost is the price that one could afford to pay for a centrifuge and still produce enriched uranium at a price competitive with that given by US price list in circulation at that time. Kistemaker arrived at these figures by assuming that the power requirement would be about 100 watts per machine and that the total capital cost of a centrifuge plant would be twice the cost of the centrifuges alone. Kistemaker concludes by expressing the opinion that it appears doubtful that model A could be produced for \$85 per machine; it is possible that model B could be produced for \$200 per machine; and that there is a very good chance of producing models C and D for less than \$750 per machine. It should be pointed out that C and D are supercritical machines. Concerning this, Kistemaker said in the 1958 paper, "We in Amsterdam have high hopes of surpassing difficulties with the gas extraction and those of passing the criticals."

**DELETED**

40E  
1.4(6)

The Dutch centrifuge program was classified late in 1960 by the Government of the Netherlands at the request of the United States.

**DELETED**

40E  
1.4(6)

That the Netherlands was quite actively interested in the centrifuge process early in 1963 was evidenced by their request that the United States help them get copies of certain East German centrifuge patents which were in the possession of the West German Government. In May of 1963 the Netherlands announced the fact that they were embarking on a three year centrifuge development program which, if successful, would lead to a pilot plant for U-235-U-233 separation. A special research facility for gas centrifuge work is being constructed at Duivendrecht, a suburb of Amsterdam for this purpose.

Evaluation of Program. It should be evident from the foregoing description of the centrifuge development work in the Netherlands that so little information is available that it is practically impossible to make any evaluation of the Dutch program. One is forced, then, merely to speculate concerning the nature of their program and the direction it is taking.

DOE  
1.4(6)

**DELETED**

It would be presumed from Kistemaker's presentation that the Dutch program was concerned primarily with the development of a supercritical machine. The lack of any subsequent information on the Dutch program is indicative only of the fact that they have maintained an effective security program in this area.

#### WEST GERMANY

Historical Background. The German centrifuge program has, up to the present time, consisted of two separate and distinct development efforts. One part of the program has been the centrifuge project located at the University of Bonn, directed by Dr. W. Groth. This work is a continuation of the German wartime work and has been quite active since 1954. Dr. Martin's work at the University of Kiel is considered to be a part of this program. The other part of the German program was carried on at the laboratories of DEGUSSA in Frankfurt where Dr. G. Zippe supervised the development efforts. This work was a continuation of the Russian post-war centrifuge work in that it was based on the centrifuge which was developed by the Russian centrifuge group of which Dr. Zippe was a member. This project has been under way for about four years.

Dr. Groth's work at Bonn was unclassified until the end of 1960 when the West German Government followed the recommendation of the USAEC and

classified all further developments in centrifuge technology. Much of the significant open literature on the gas centrifuge has been contributed by this group of investigators. This program has always had a strong engineering emphasis. The work has been directed toward the development of mechanically reliable centrifuges. ~~DELETED~~

DOJ  
17(b)

Their program can be summarized most conveniently by considering the various centrifuges they have either constructed or plan to construct. The characteristics of these centrifuges are listed below.

Centrifuge	Length, cm	Radius, cm	Length-to- Diameter Ratio	Peripheral Speed, m/sec	Separative Capacity, kg U/yr
UZ-I	40.0	6.0	3.33	302	0.582
UZ-III B	63.5	6.7	4.74	302	0.935
ZG-3	66.5	9.25	3.60	302	0.97
ZG-5	113.0	9.25	7.03	302	1.64

DOJ  
14(b)

**DELETED**

Model UZ-I was constructed during World War II and was successfully separating the isotopes of uranium early in 1942. In 1943 a double centrifuge unit, the UZ-III A, was built. This machine, which consisted of two rotors spinning in opposite directions with a cyclical fluctuation in speed in order to provide the gas flow between them, was to be the basic processing unit of the German uranium isotope separation plant. Although completed, the UZ-III A was damaged by the war before any UF<sub>6</sub> tests could be made. After the war an improved machine, the UZ-III B, was built which had the same dimensions as the UZ-III A but it, as well as all subsequent models, employed heated end caps to provide the internal countercurrent flow. The structural details of, and the experimental results from, the UZ-III B have been published in several places. A good review of this work was presented by Groth and Beyerle<sup>(13)</sup> in 1958.

The ZG-3 centrifuge was described by Groth<sup>(14)</sup> at Geneva in 1958 and some data were presented on the separation of the isotopes of argon and xenon. Although Groth stated that the ZG-5 was already in operation in 1958, no data on the ZG-5 experiments were reported until a 1960 paper<sup>(3)</sup> which dealt with the separation of the isotopes of argon.

The separative efficiencies have been computed for several of Groth's machines from his experimental data and are presented below.

<u>Centrifuge</u>	<u>Process Gas</u>	<u>Peripheral Velocity, m/sec</u>	<u>Separative Efficiency, %</u>
UZ-III B	UF <sub>6</sub>	252	70
	UF <sub>6</sub>	280	74
ZG-3	argon	268	30
	argon	302	23
	xenon	268	36
	xenon	302	30
ZG-5	argon	298	39

Groth was apparently disappointed by the low separative efficiencies obtained with the ZG-3 and ZG-5. The last paper published by the group at Bonn<sup>(15)</sup> deals with the possibility of increasing the separative efficiency of his centrifuges by impressing a radial temperature gradient across the end caps. The meager data presented in this article indicate that an appreciable gain in efficiency may be attained in this manner. It is doubtful that there will be any further publications by this group in the open literature until such time as the German Government changes its classification policy regarding the centrifuge process.

Several nuclear research institutes have been established by the German Federal Republic. Groth is now supported in his research work by the Society for the Support Nuclear Science and Research of the state of Nord Rhein-Westphalia. Part of this research organization is the Institute for Scientific Apparatus, Measuring and Control Engineering, Aachen, of which Dr. Konrad Beyerle is director. Several members of the staff were transferred from the Institute of Instrument Design of the Max Planck Society, Gottingen, which under Beyerle's direction designed the earlier centrifuges used by Groth.

DELETED

DELETED

DOE  
1.4(b)

DOE  
1.4(b)

DELETED

Another Boyerle-designed centrifuge was put in operation in the summer of 1958 at Kiel Institute for Physical Chemistry, Kiel, which is headed by Dr. Hans Martin. The unit is similar to those used by Groth in Bonn. Martin's centrifuge is mounted vertically and is about 4-1/2 feet long. Martin is continuing his theoretical studies on the theory of gas flow inside the centrifuge bowl.

DELETED

DOE  
1.4(b)

The centrifuge developed by Dr. Groth at Bonn is a relatively complex machine compared with the centrifuge model which was developed in Russia after the last war (1946-1954) by a group headed by Dr. Max Steenbeck. Dr. G. Zippe, an Austrian who was interned by the Russians and who was a member of Steenbeck's group, came to the United States after his release by the Russians and in the period from July 1958 to June 1960 duplicated at the University of Virginia the machine which had been developed in Russia. This centrifuge, which differs from the Groth-type centrifuge primarily in that it eliminates the need for complicated seals and bearings, has been termed the Zippe-type machine throughout this report. At approximately the same time that Zippe was duplicating the Russian machine at the University of Virginia, an associate of his on the Russian project, Rudolf Scheffel, was doing the same work in Frankfurt for DEUSSA. These two men had an agreement with one another regarding their work, and when Zippe's contract at Virginia was terminated he joined Scheffel at DEUSSA.

DELETED

DOE  
1.4(b)  
1.4(b)



~~SECRET~~

27

POE  
1.4(6)  
1.4(6)

**DELETED**

In connection with the German decision in 1960 to classify the centrifuge program, it was their stated intention to consolidate all of the centrifuge development work in a new facility at Julich, near Aachen. Neither of the groups concerned was at all happy with this arrangement; nevertheless Zippe said they are planning to move all of the DEGUSSA centrifuge work to Julich where it will be conducted directly for the West German Government. Similarly, Groth, although he has on several occasions said that he was going to terminate his research on centrifuges because of government interference and because he has been severely hampered by his Government's security regulations, apparently agreed in mid-1963 to move his laboratory to Julich and continue his work there. It has just recently been reported that Dr. Boettcher, director of the Atomic Research Center at Julich, has applied to the Nord Rhein-Westphalia authorities and to the Ministry for Atomic Energy for approval of a proposal to establish a centrifugal separation institute at Julich. Sufficient funds were requested to employ a staff of about 100 scientists at the centrifugal institute. Fifty percent of the total expenditure would be met by the state of Nord Rhein-Westphalia and 50% by German Federal Government. The DEGUSSA group, under Dr. Zippe and Dr. Scheffel, would form the nucleus of the centrifugal research staff. The total number of German scientists currently engaged on the project is less than 25. However, Dr. Boettcher's

~~SECRET~~

plans are approved by some individual members of the supervisory board in  
Polish, and no decision has yet been reached.

Evaluation of Program.

DOE  
1.4(B)  
1.4(C)

**DELETED**

The interest which Groth, a professor at the University of Bonn, has in  
the centrifuge process is probably primarily scientific and professional.  
His name has been associated with centrifuges for a long time, and the  
development of a successful centrifuge process would be a singular personal  
achievement.

The interest shown by the German Government evidenced by its support of  
the centrifuge project is much more difficult to assess. It is granted  
that the German Government is interested in supporting scientific  
activities at its institutes and universities.

DOE  
1.4(C)

**DELETED**

DOE  
1.4(C)

DELETED

OTHER SECTION REFERENCES

DOE  
1.4(C)  
1.4(B)

DELETED

France

DOE  
1.4(B)

DELETED

DELETED

DOE  
1.4(C)  
1.4(B)

JUN 5 1970

~~SECRET~~

100

#### ACKNOWLEDGEMENTS

The authors wish to acknowledge the assistance given them in the preparation of this report by the Plant Engineering and Technical Divisions of ORGDP, the Technical Division of Y-12, and the centrifuge groups at AiResearch and the University of Virginia.

~~JRD~~

~~SECRET~~

REFERENCES

- 1 Levin, S. A., Hatch, D. E., and Von Halle, E., Production of Enriched Uranium for Nuclear Weapons by Nations X, Y, and Z by Means of the Gas Centrifuge Process, Union Carbide Corporation, Nuclear Division, Oak Ridge Gaseous Diffusion Plant, February 26, 1960, KOA-652.
- 2 Garrett, G. A., Levin, S. A., and Von Halle, E., Review of the Gas Centrifuge Process and Evaluation of Foreign Centrifuge Programs, Union Carbide Corporation, Nuclear Division, Oak Ridge Gaseous Diffusion Plant, October 30, 1961, KOA-916.
- 3 Bulang, W., Grotz, W., Jordan, I., Kolbe, W., Mann, E., and Welge, K. H., "On the Separative Capacity of Thermally Driven Countercurrent Gas Centrifuges," Z. Phys. Chem. (Frankfurt) 24, 249-64 (1960).
- 4 Garrett, G. A., Vanstrum, P. R., and Kuhlthau, A. R., Report on Meetings with the UKAEA in England, December 12-15, 1960, Union Carbide Corporation, Nuclear Division, Oak Ridge Gaseous Diffusion Plant, February 20, 1961, KB-852.
- 5 Vanstrum, P. R., Evans, E. C., and Levin, S. A., Report on Meetings with UKAEA Representatives at the University of Virginia, July 19-20, 1961, Union Carbide Corporation, Nuclear Division, Oak Ridge Gaseous Diffusion Plant, August 23, 1961, KB-878.
- 6 Friedericy, J. A., Meeting with UKAEA Representatives at the University of Virginia, Charlottesville, Virginia, July 19-20, 1961, University of Virginia, August 1961, EP-4422-161-618.
- 7 Levin, S. A. and Von Halle, E., Report on Visit to Centrifuge Facilities at Capenhurst, England, June 14, 1962, Union Carbide Corporation, Nuclear Division, Oak Ridge Gaseous Diffusion Plant, February 14, 1963, KOA-1127.
- 8 Lang, D. M., Leed, R. E., Lowry, R. A., Parker, H. M., Vanstrum, P. and Woolworth, L. R., Report on Visit by US Gas Centrifuge Team to U.K., May 27-30, 1963, Union Carbide Corporation, Nuclear Division, Oak Ridge Gaseous Diffusion Plant, September 27, 1963, KL-1670.
- 9 Kolstad, G. A., Discussions with Germans and Dutch on Centrifuge Collaboration, FUR-90, July 1958.
- 10 Kistemaker, J., Los, J., and Veldhuyzen, E. J. J., "The Enrichment of Uranium Isotopes with Ultracentrifuges," Proceedings of the Second United Nations Conference on Peaceful Uses of Atomic Energy, Geneva, Vol. 4, 435-8 (1958).

11. Los, J. and Kistemaker, J., "On the Influence of Temperature Distribution Inside a Gas Centrifuge," Proceedings of the International Symposium on Isotope Separation, North Holland Publishing Company, Amsterdam, 695-700 (1958).
12. Netherlands Patent No. 87,740, To Reactor Centrum Nederland, February 16, 1958.
13. Beyerle, K. and Groth, W., "Enrichment of the Uranium Isotopes by the Gas Centrifuge Process," Proceedings of the International Symposium on Isotope Separation, North Holland Publishing Company, Amsterdam, 667-94 (1958).
14. Groth, W., Beyerle, K., Mann, E., and Welge, K. E., "Enrichment of the Uranium Isotopes by the Gas Centrifuge Process," Proceedings of the Second United Nations Conference on Peaceful Uses of Atomic Energy, Geneva, Vol. 4, 439-46 (1958).
15. Bulang, W., Groth, W., and Mann, E., Z. Physik. Chem. (Frankfurt) 25, 283-5 (1960).